



skanti

INSTRUCTION MANUAL

SSB RECEIVER
Type R400

Radiotelefonimodtager type R 423.

Radiotelefonimodtager type R 423 er en speciel version af type R 400 og adskiller sig fra denne på følgende punkter:

1. Modtageren er indrettet for 75 ohm antenneimpedans i frekvensområdet 1,6-4 MHz.
2. Duplex-forkredsene i HF båndene 4-22 MHz er justeret til at dække skibssendefrekvenserne mod normalt kyststationernes sendefrekvenser. (SERVICE-omskifter indstillet til semi-duplex eller duplex):

BÅND	FREKVENSBOMRÅDE, kHz
4 MHz	4063 - 4139,5
6 MHz	6200,8 - 6213,5
8 MHz	8195 - 8284,4
12 MHz	12330 - 12428
16 MHz	16460 - 16572
22 MHz	22000 - 22108,5

3. 600 ohm linieudgang med særskilt volumenkontrol ført ud på frontpladen (dobbelt knap ved AF GAIN). Linieudgangen, som er uden midtpunktsudtag, er tilsluttet terminalerne 107 og 108 i multistikket og er isoleret fra chassis. Udgangseffekt 30 mV i 600 ohm. Udgangsimpedans 40 ohm.

Ændringer i stykke:

② CT FRONT END

2C3 udgår

2L1 ændres til SKANTI CODE: R-0393

2T1 ændres til SKANTI CODE: R-0391

2T2 ændres til SKANTI CODE: R-0392

③ HF COIL SECTION

3C13, 3C37, 3C61 ændres til 180 pF, 5%, 400 V, Cer. N150

3C14, 3C38, 3C62 ændres til 150 pF, 5%, 400 V, Cer. N150

3C15, 3C39, 3C63 ændres til 110 pF, 5%, 400 V, Cer. N150

3C16, 3C40, 3C64 ændres til 100 pF, 5%, 400 V, Cer. N150

④ -mod. AF AMPLIFIER-600Ω

Som linieudgangsforstærker er mellem forplade og mellemforplade monteret et ekstra modul ④ modificeret på flg. punkter (diagram R-0360):

7D1 - 7D5 udgår

7R2 udgår (kortslettes)

7R4 ændres til 10 ohm, 5%, 1/8W, Car.

7R5 udgår

Tilføjes: 1 stk 100 μF, 16 V, W.alum.

1 stk 5,6 kohm, 5%, 1/8W, Car.

1 stk TO-5 kølefinne

Terminalerne 5, 6, 9 og 10 afklippes

①⑦ CHASSIS (electrical parts)

17R5 ændres til 10 kohm + 10 kohm, log, Var. Car. (twin). :R-0405-1

Ekstra knap 021-332 + dæksel 040-302

R423 Wiring diagram: R-0404-1

7AA 300 (BOTTOM VIEW)

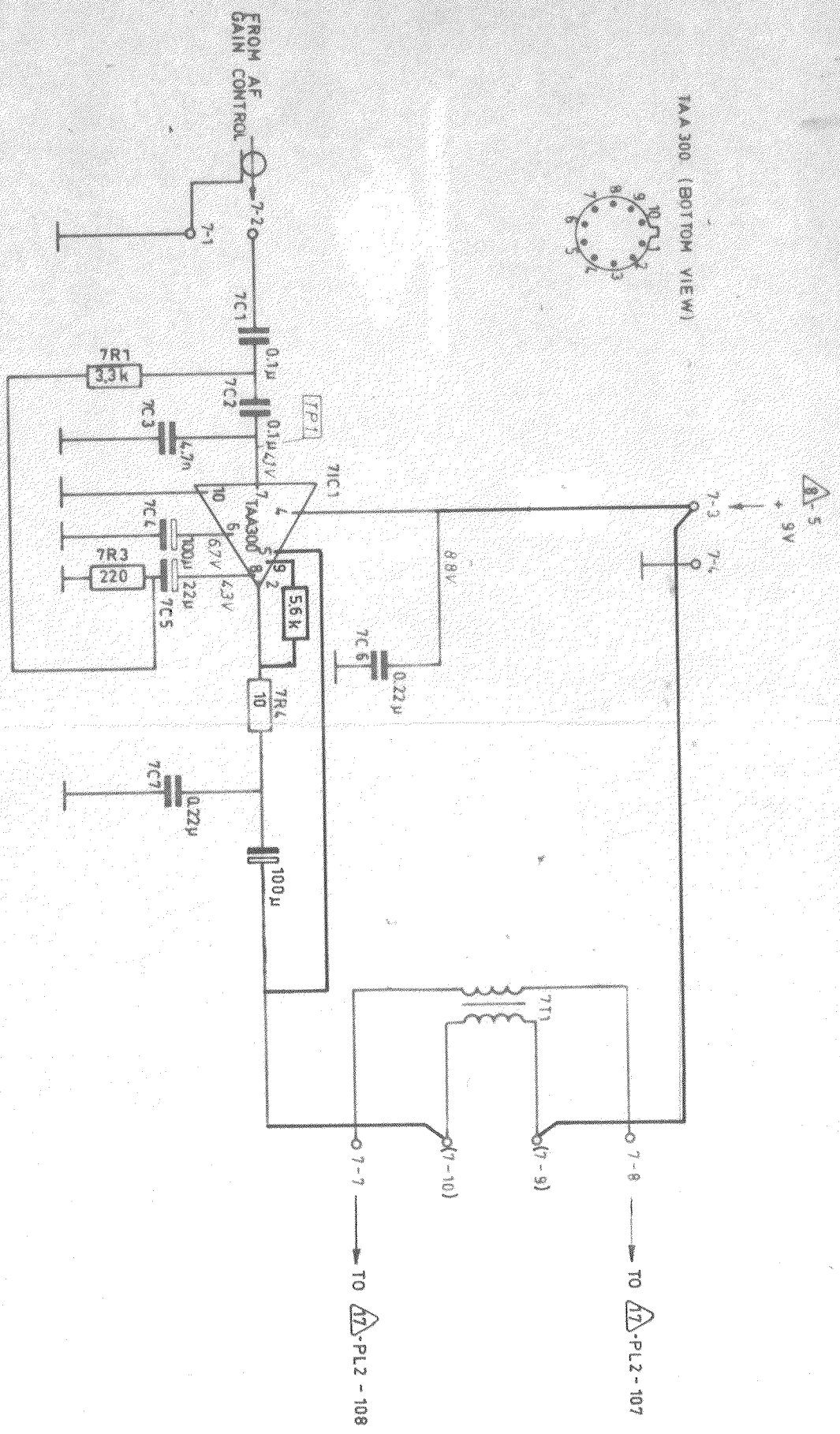
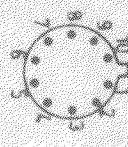

R - 0360 - 1 AF AMPLIFIER - 600A



R 400
INSTRUCTION MANUAL
CONTENTS

- Technical Data
1. Introduction
 2. Technical Description
 3. Installation
 4. Operating Instructions
 5. Simple Service
 6. Repair and Alignment
 7. Parts Lists and Circuit Diagrams

R 400
INSTRUCTION MANUAL
CONTENTS

Technical Data

1. Introduction
2. Technical Description
3. Installation
4. Operating Instructions
5. Simple Service
6. Repair and Alignment
7. Parts Lists and Circuit Diagrams

Type R 400

SSB Maritime Radiotelephone Receiver

Technical Data

Modes

A3, A3H and A3A, A3J.

Operating Frequencies

30 spot frequencies in the coastal telephony band (CT) 1605-4000 kHz.
8 spot frequencies in each of the seven HF bands between 4 and 27.5 MHz allocated to the Maritime Mobile Radiotelephony Service, except the 6 MHz and 25 MHz bands where four spot frequencies are provided.

Frequency Accuracy

±100 Hz.

Frequency Fine Tuning

Frequency error can be reduced to less than 10 Hz by means of a CLARIFIER control, the frequency variation of which is more than ±200 Hz at less than 2 Hz per degree of rotation.

Frequency Stability

20 Hz in any 15-minute period.

Selectivity

A3A, A3J:

Less than 6 dB attenuation at 350 to 2700 Hz relative to carrier frequency.
More than 60 dB attenuation at -500 and +3400 Hz.

A3, A3H:

Less than 6 dB attenuation at -2.7 to +3.5 kHz.
More than 60 dB attenuation at +10 and -10 kHz.

Sensitivity

Better than

A3, A3H : IF band : 32uV for 20 dB SINAD
 : HF bands : 18uV for 20 dB SINAD

A3A, A3J : IF band : 6.3uV for 20 dB SINAD
 : HF bands : 3.5uV for 20 dB SINAD

Automatic Gain Control

A 70 dB increase in input signal level from nominal sensitivity levels will not increase the output by more than 10 dB.

Blocking

Undesired carrier 100 dB above 1uV, 20 kHz off tune, will not change the output by more than 3 dB. Desired signal 60 dB above 1uV.

Cross Modulation

Undesired signal 90 dB above 1uV, 20 kHz off tune, will not cause any cross modulation component of more than 33 dB below the desired output. Desired signal 60 dB above 1uV.

RF Intermodulation

Two undesired signals, both 80 dB above 1uV, more than 30 kHz off tune will not produce an output exceeding that of a desired signal of 30 dB above 1uV.

Intermediate Frequency Rejection Ratio

Better than 90 dB in the bands below 5 MHz and better than 60 dB in the bands above 5 MHz.

Image Rejection and Other Spurious Responses

Better than 60 dB.

Nonlinear Distortion

Less than 10% at rated output power for any input level between 30 dB and 100 dB above 1uV.

AF Intermodulation

Below -35 dB relative to each tone.

AF Response Characteristic

Within 6 dB, 350 Hz to 2700 Hz, below -15 dB at 100 Hz.

Audio Output

Built-in loudspeaker : 500 mW
Facility for connecting an external loudspeaker (4 ohms)
External loudspeaker : 1 W (at nominal supply voltage)

Radiation

Less than 400pW, RF voltage less than 90uV measured at aerial terminal.

Front End Protection

The receiver is capable of withstanding an e.m.f. of 30V applied to its aerial terminals via the proper dummy aerial, at any frequency in the maritime mobile bands between 400 kHz and 27.5 MHz for 15 minutes without damage.

Controls

BAND switch
CHANNEL switch
CT PRESELECTOR
SERVICE switch (MAINS OFF - simplex - semiduplex - duplex)
MODE switch (A3, A3H - A3A, A3J)
CLARIFIER
AF GAIN control
RF GAIN control combined with AGC ON-OFF switch
LOUDSPEAKER ON-OFF switch

Supply Voltage

12/24V battery (built-in power pack: R-0290) or
110/220/380/440V AC, 50-60 Hz (built-in power pack: R-0289)

Supply Voltage Variations

DC: 10.6-33V
AC: $\pm 10\%$

Power Consumption

DC: 1.1A (10.6-33V)
AC: 22VA

Environmental Conditions

Ambient temperature range: -15 to +55°C
CEPT and MPT 1204 (UK) vibration test, extended range.
CEPT and MPT 1204 (UK) damp heat test.

Dimensions

Rack-mounted	: height	: 132.5 mm
	width	: 482 mm
	depth - into rack	: 363 mm (connectors incl.)
	depth - overall	: 406
	weight	: 9.7 kg
Cabinet-mounted	: height	: 165 mm (shock absorbers incl.)
	width	: 490 mm
	depth - overall	: 410 mm (connectors incl.)
	weight	: 15.4 kg

TYPE R400 TELEPHONY RECEIVER

Calculation of channel crystal frequency f_x from receiving frequency f_r .

Note that the receiving frequency is always the carrier frequency.

All frequencies are in kHz.

Band	f_x Channel crystal frequency
1605-4000 kHz	$f_r + 500$ kHz
4 MHz	$f_r + 500$ kHz
6 MHz	10700 kHz - f_r
8 MHz	10700 kHz - f_r
12 MHz	$f_r - 10700$ kHz
16 MHz	$f_r - 14900$ kHz
22 MHz	$f_r - 20500$ kHz
25 MHz	$f_r - 23300$ kHz

Channel crystals with specification according to SKANTI specification R-0328 are marked with f_r on the case top and with f_x on the case side.

CHANNEL CRYSTAL SPECIFICATION

Holder: HC-6/U

Frequency: 1.6-6 MHz

Tolerance: a) $\pm 0.002\%$ at 24°C
b) $\pm 0.001\%$ variation from 24°C
over temperature range

Temp. range: -20 to $+70^{\circ}\text{C}$

Circuit: Parallel resonance, 30 pF

Drive: 1mV

Activity: DEF 5271-A

Operating mode: Fundamental

Marking: Case top: to be specified in order
Case side: R-0328 and nominal crystal frequency

1. INTRODUCTION

- 1.1. The R 400 is a single and double sideband radiotelephone receiver for telephony communication in the 1.6-4 MHz coastal telephony band and the 4-27.5 MHz maritime high-frequency telephony bands. The receiver is crystal controlled and has a total of 78 channel facilities distributed as follows: 30 channels in the coastal telephony band and 8 channels in each high-frequency band except the 6 and 25 MHz bands each of which has 4 channels.

The receiver is designed for reception of type A3, A3H and upper-sideband A3A and A3J signals. It is fully transistorized, and wide-spread use is made of integrated circuits. These features in connection with the fact that no crystal ovens are used cause the receiver to be ready for operation immediately after having been switched on.

The receiver incorporates a monitoring loudspeaker, but an external loudspeaker may be connected if desired.

Depending on the power pack installed in it, the receiver can be powered from a 12V or 24V battery or from AC voltages normally occurring in practice.

Adding new channels to the receiver is very simple. The only adjustment required is adjustment of the crystal frequency. The crystals become accessible after removal of the top cover plate of the receiver. Crystal trimmer capacitors permit making correction for the natural ageing of the crystals which might otherwise within a few years bring the frequencies outside the specification limits.

The dimensions match a 19-inch standard rack, and the receiver is intended for mounting in the same cabinet with the Type T 400 transmitter. When so mounted, the receiver and transmitter in conjunction with the transmitter power pack constitute the TRP 400 transmitter/receiver combination. The receiver is also available as a separate cabinet model.

Because we at Skanti are constantly processing the experience gained during the production and operation of our equipment, it is possible for minor modifications to occur relative to the information given in this instruction manual. Wherever practicable, however, any corrections will be listed on a correction sheet at the back of the front cover of this manual.

2. TECHNICAL DESCRIPTION

2.1. For Technical Data see first page of this manual.

2.2. Construction

The receiver is built on a rugged alodine treated aluminium chassis which is designed so that it also provides RF screening between the various receiver sections. The chassis has four outside cover plates. These provide internal screening in the receiver as well as protecting it from direct signal pick-up from outside.

The front panel is electrically insulated from the chassis. This feature permits connecting the chassis to a separate earth when the receiver is mounted in the same rack with the transmitter.

The receiver is divided into 18 modules most of which are built on printed circuit boards. All of these, except module No. 10 become accessible when the cover plates are removed. Module No. 10 containing the clarifier oscillator is housed in a special screen can in order to prevent oscillator radiation. The number of leads to the individual modules has been kept to a minimum, in part due to the use of diode switches.

The chassis divides the receiver into five sections. In the front compartment, behind the front panel, switches and potentiometers are located so as to be easily accessible when the front panel is removed. Here, too, is the power pack - AC or DC. The top compartment contains the channel crystal oscillator module 9, which has 78 crystal sockets. The left side compartment houses modules 4 to 7 inclusive; these are part of the signal path from the first mixer to the audio amplifier. The right side compartment encloses module 8, the 9V voltage regulator, and modules 11 to 15 inclusive all of which are part of the frequency-generating functions. The lower part of the chassis is divided into two compartments. The larger compartment houses the CT front end, module No. 2, and the HF coil section, module No. 3. The smaller compartment contains RFI filters, module No. 16, and the clarifier oscillator, module No. 10.

2.3. Circuit Description, General

2.3.1. The circuit diagram is divided into a wiring diagram on page 7-75 showing interconnections between the individual modules; and circuit diagrams of individual modules. Circuit diagrams of the integrated circuits are included in the interest of clearness. This does not apply to the digital circuits, where only the logic symbols are shown. The mode of operation follows from block diagrams on page 7-40 and page 7-41 showing the signal path and the process of frequency generation, respectively.

2.3.2. The incoming signal is fed via the "SERVICE" switch and the "BAND" switch to the CT front end $\triangle 2$ or the HF coil section $\triangle 3$. The HF coil section has two sets of input filters for each band, permanently tuned to the simplex and duplex channel frequencies in each of the high-frequency bands. With the "SERVICE" switch at "simplex", the incoming signal is fed to the simplex filters. In the "semi-duplex" or "duplex" position, the signal is fed to the duplex filters. With the "BAND" switch at "CT", the signal is fed to the CT front end in either case.

In the "simplex" position, a pair of clipper diodes are connected across the aerial input to protect the simplex input circuits against one's own transmitter.

Bandswitching between the input filters is carried out in the "BAND" switch, from where coaxial cables go to the respective inputs. The outputs are switched by diodes. Switching voltage, 9V, is applied via the coaxial cables at the inputs.

From the output of the RF stages, the signal is fed to the 1st mixer module, $\triangle 4$, where it is converted to the intermediate frequency, 500 kHz (CT and 4 MHz bands) or 10.7 MHz (other HF bands). The selectivity of the intermediate-frequency filters permits a double-sideband signal to pass through.

Module $\triangle 5$ contains the 1st intermediate-frequency amplifier, 2nd mixer, and 2nd intermediate-frequency amplifier. The 2nd mixer converts the signal to 1.4 MHz, where a crystal filter determines the ultimate selectivity of the receiver. The "MODE" switch selects between a single and a double sideband filter.

From the 2nd intermediate-frequency amplifier, the signal is fed to module No. $\triangle 6$, which contains the signal and AGC detectors. The radio-frequency amplifiers and both intermediate-frequency amplifiers are AGC-controlled. Advancing the "RF GAIN" control will disable the AGC, and the gain is thereafter controlled by a DC voltage taken off across the "RF GAIN" potentiometer. The audio signal from the detector is fed via the "AF GAIN" potentiometer to module No. $\triangle 7$, the AF amplifier.

The output transistor of the AF amplifier receives its supply voltage directly from power pack $\triangle 18$ or $\triangle 19$ whereas all other circuits of the receiver are powered from a stabilized +9V supply (voltage regulator, module No. $\triangle 8$).

2.3.3. The injection frequencies for the 1st and 2nd mixers and for the product detector are generated on the basis of the frequencies supplied by channel oscillator $\triangle 9$, clarifier oscillator $\triangle 10$ and a highly stable temperature-compensated crystal oscillator, master oscillator $\triangle 11$.

In the CT, 4, 6, 8 and 12 MHz bands, the channel oscillator is connected directly to the 1st mixer. In these bands, the injection frequency is lower than 5 MHz. In the 16, 22, and 25 MHz bands, the injection frequency is higher; it is generated in a phase-locked loop composed of the voltage-controlled oscillator $\triangle 13$ and loop mixer and phase detector $\triangle 14$.

The output frequency of the voltage-controlled oscillator is equal to the sum of the channel oscillator frequency and an auxiliary frequency derived from the highly stable master oscillator signal. In the three bands, the auxiliary frequency is equal to the 3rd, 7th, and 9th harmonics, respectively, of 1.4 MHz, and the desired frequency is selected in module No. (15).

The output signal from the 2nd mixer is at 1.4 MHz. The injection frequency is 900 kHz in the CT and 4 MHz bands, where the 1st intermediate frequency is 500 kHz, and is supplied by the clarifier oscillator, (10).

The clarifier oscillator is crystal controlled but its frequency can be varied, with the "CLARIFIER" control, +/-200 Hz from the centre frequency so as to compensate for minor deviations between the transmitter and receiver frequencies. In the other bands, where the 1st intermediate frequency is 10.7 MHz, the injection signal is 12.1 MHz. It is generated by mixing the 900 kHz clarifier signal and an 11.2 MHz signal from the master oscillator. The 12.1 MHz mixer is module No. (12).

.4. Circuit Description, Individual Modules

(2) CT Front End

The coastal telephony band front end is tuned with a 3-gang capacitor, operated with the "CT PRESELECTOR" control on the front panel. The signal-frequency circuits constitute a double band-pass input filter. The neon lamp across the first tuned circuit and the diodes across the input of the integrated amplifier protects against high incoming-signal voltages. The output signal is fed from the coupling winding of the output circuit to the 1st mixer via a diode switch in the HF coil section. Switching voltage is applied via the "BAND" switch through the coupling windings of the input and output circuits.

(3) HF Coil Section

All circuits of the HF coil section are fixed tuned. The input filters have a bandwidth covering all channels of each of the maritime frequency bands for simplex and duplex radio telephony communication, respectively. The duplex filters comprise three tuned circuits, and their selectivity is high to provide effective attenuation of one's own transmitter. Band-switching is performed via the coaxial cables at the inputs. The inner conductor of the coaxial cable in use feeds a DC voltage to the diode switches at the filter output and in the intermediate tuned circuit of the corresponding band. The RF amplifier consists of an integrated circuit which has been developed specifically for this purpose and is remarkable for its ability to handle high signal levels.

4 1st Mixer

The mixer stage is an integrated circuit containing a double balanced mixer. The mixer output is connected either by diode switching, to a four-pole LC filter tuned to 500 kHz or to a 10.7 MHz crystal filter. Switching is controlled from the band switch. The balanced mixer configuration provides a high order of intermediate-frequency rejection. At 500 kHz, additional intermediate-frequency rejection is provided by the series trap across the signal input. Also included in the input circuit are a 30 MHz lowpass filter and a series trap tuned to 11.74 MHz.

5 IF Amplifiers and 2nd Mixer

The 1st intermediate-frequency amplifier consists of integrated circuit 5 IC 1. Between the output of this integrated circuit and the 2nd mixer, 5 IC 3, are two series-tuned circuits at 500 kHz and 10.7 MHz, respectively. The mixer receives a balanced injection signal from 5 IC 2, which functions as an amplifier and amplitude limiter. The two 1.4 MHz filters between the mixer and the 2nd intermediate-frequency amplifier are a double-sideband and a lower-sideband crystal filter, respectively. The AGC control range in the 2nd intermediate-frequency amplifier is approx. 10 dB, and control is effected by varying the emitter bypass in the first state.

6 Detectors and AGC Amplifiers

Switching between A3, A3H and A3A, A3J is performed via terminal 6-7, connected by the "MODE" switch to 0V or +9V, respectively. In both switch positions, the signal detector is integrated circuit 6 IC 1, which contains a balanced mixer and a high-gain limiting amplifier.

A3, A3H:

Signal voltage from the 2nd intermediate-frequency amplifier is fed to the balanced mixer at terminal 7 of 6 IC 1. The signal is also fed via emitter follower 6 TR 2 to the limiting amplifier (terminal 14) which removes modulation from the signal by amplifying it and clipping it to constant amplitude. The amplifier output is internally connected to the other input of the balanced mixer, where the signal functions as injection signal and is mixed with the modulated signal. The audio signal is taken off at terminal 8 across the built-in collector resistor which combines with the capacitor across the output to form a low-pass filter which only permits the audio signal to pass through. This is thereafter fed via emitter follower 6 TR 4 to output terminal 6-8. AGC voltage is produced by rectifying the 1.4 MHz signal after amplification in 6 TR 3 and is taken off across emitter follower 6 TR 5.

A3A, A3J:

The signal detector functions in the same manner as in A3, A3H except that the 1.4 MHz injection signal is applied from the master oscillator. Transistors 6 TR 2 and 6 TR 3 are inoperative in this switch position.

AGC voltage is provided by the detected audio signal in the AGC generator, 6 IC 2. This circuit combines very short attack time and long hold-time (the AGC level is maintained during speech pauses with high immunity to noise pulses). In addition it will follow varying signal levels smoothly under conditions of fading. The circuit contains two detectors having short and long rise and fall time constants respectively, and a hold circuit which is triggered when the audio signal disappears suddenly. The audio signal will rapidly establish an AGC level via the detector having a short rise time constant. Meanwhile the output of the long time constant detector will rise and take over control after some time. In speech pauses, the AGC voltage from this detector will be kept constant by the hold circuit, which is triggered if the signal variation exceeds 20 dB/sec. The AGC voltage will not hang on brief noise pulses as these will only activate the detector having the short rise time constant. The short rise time constant is approx. 4 msec and the hold time is approx. 2 sec.

7 AF Amplifier

The input signal from the "AF GAIN" potentiometer is fed to integrated amplifier 7 IC 1 via capacitors 7 C 1 and 7 C 2, which are part of an active high-pass filter which determines the lower cut-off frequency of the amplifier.

The integrated amplifier is DC coupled to the output transistor, which operates in Class A. Zener diodes across the output transformer protect the transistor when the transformer is not loaded. Since the output transistor operates in Class A it will not burn out even if the AF output is short-circuited.

8 9V Voltage Regulator

This circuit contains a voltage regulator circuit and an over-current protection circuit. By means of resistors 8R7 and 8R8 a fraction (fine-adjusted by 8R8) of the output voltage is taken off and compared in 8TR2 with the reference voltage across 8D8. The collector of 8TR2 is connected to the series regulator composed of 17TR2 and 8TR1, a so-called PNP super Darlington stage.

In order to start the regulator, the base of 8TR2 must receive a starter current through capacitor 8C1. When the receiver is switched off, the capacitor discharges through a resistor in power pack 18 or 19.

The current-limiting properties of this circuit are due to the fact that emitter resistors 8R5 and 8R6 determine the amount of current that can be drawn by 8TR2 before the zener voltage across 8D8 collapses. When the zener voltage collapses, the regulator will reduce the output voltage, thereby causing the voltage drop across the zener diode to become even smaller - in other words, the circuit is regenerative, and the output voltage will rapidly drop to 0. When the current limiter has operated it will be necessary to switch off the receiver for approx. 3 seconds so that 8C1 will have time to discharge. The variable emitter resistor, 8R6, permits adjustment of the current at which the limiter will operate. 8R6 is factory pre-set to cause limiting to occur at a load of approx. 2A.

9 Channel Oscillator

Crystals are switched in a diode matrix. To select a particular crystal, +9V is fed by the "CHANNEL" switch to the appropriate column terminal, and the "BAND" switch applies 0V to the row terminal.

The oscillator employs transistor 9TR1. The oscillator output signal is applied to a buffer stage, 9TR2, followed by an emitter follower, 9TR3. From the emitter follower, the signal is fed to the output terminal and to an amplifier stage, 9TR4. The output of this amplifier stage is rectified by 9TR5, and the amplified DC signal is fed back to the base of 9TR1, which controls the oscillator gain. This control system means that the level is kept constant and that the content of harmonics of the crystal frequency will be low.

10 Clarifier Oscillator

The oscillator is crystal controlled and operates at 3.6 MHz. The frequency can be varied +/-800 Hz by means of the variable inductance in series with the crystal. The amplifier section consists of two series-connected NAND gates with negative DC feedback. The 3.6 MHz signal is fed to frequency divider 10IC2, which contains two series-connected flip-flops. The output frequency is 1/4 of the input frequency; that is, 900 kHz +/-200 Hz. The signal is fed to the output terminal via a series tuned circuit.

11 Master Oscillator

The master frequencies are generated from a highly stable temperature compensated crystal oscillator, TCXO, at 5.6 MHz. The term master frequency means signals which are harmonics or subharmonics of the TCXO frequency of 5.6 MHz. The sinusoidal output signal of the TCXO is amplified and clipped by transistors 11TR1 and 11TR2. The signal from the collector of 11TR2 is fed to a resonant circuit tuned to 11.2 MHz (2nd harmonic) and to frequency divider 11IC1. This integrated circuit, which divides the TCXO frequency by 4 to 1.4 MHz, consists of two series-connected flip-flops. From the output of the divider, a 1.4 MHz signal is fed to a BNC connector on the rear wall for connection to a SKANTI Type T 400 transmitter, to the product detector for carrier re-insertion, and to filters 15. The module has two +9V terminals so that it can be powered from the transmitter with the receiver turned off. Crystal oscillator ageing is very small (less than 10^{-6} per annum) and will be greatest during the first few years. Ageing will normally cause an increase in frequency, which can be compensated by introducing the connection indicated by the dotted line in the circuit diagram. This will reduce the frequency by approx. 2×10^{-6} .

12 12.1 MHz Mixer

In the mixer, the 900 kHz signal from the clarifier oscillator is added to the 11.2 MHz signal from the master oscillator. The sum signal is taken out across the 12.1 MHz output circuit. In the "CT" and "4MHz" ranges, transistor 12TR1 conducts and so cuts off the 11.2 MHz amplifier; at the same time the balanced mixer is thrown out of balance and therefore acts as an amplifier for the 900 kHz signal. The output frequency in these ranges is consequently 900 kHz. The resonant frequencies of the two tuned circuits in the output are so widely spaced that one circuit acts as a short-circuit to a signal at the resonant frequency of the other circuit.

13 Voltage Controlled Oscillator

The oscillator receives supply voltage only when the "BAND" switch is set at 16, 22 or 25 MHz. 13TR3 is the oscillator transistor whilst 13TR4 and 13TR5 constitute a buffer amplifier. 13TR6 rectifies the signal and feeds control voltage to the base of the oscillator transistor, thus keeping the signal level constant. Band switching is performed by switching one of the coils 13L4 or 13L7 in and out of circuit. In each band, the frequency can be altered stepwise by switching in and out one or more of the four capacitances across the resonant circuit connected to 13IC1. This circuit contains four NAND gates with "open" collectors which function as switches. These are controlled from a binary 16-counter, and capacitor values are matched so that the capacitance varies in 16 steps of equal size. Inside each step the frequency can be varied continuously with capacitance diodes 13D6 and 13D7.

When the input, terminal 13-7, which is connected to the phase detector, is connected to +9V via a resistor, the hunting-oscillator will cause the frequency range to be scanned in the following manner: A charge will build up across capacitor 13C1, and this voltage is applied to the capacitance diodes. This will cause the oscillator frequency to alter continuously. When the voltage reaches approx. 7V, the hunting oscillator will be triggered because transistors 13TR1 and 13TR2 will begin to conduct, thereby rapidly discharging the capacitor. At the same time a pulse is fed to the 16-counter, causing it to take a step forward. This process will repeat itself until the oscillator reaches the correct frequency. The output voltage of the phase detector will then drop to a level below 7V, with the result that the hunting-oscillator will not be triggered. The control voltage supplied by the phase detector to the capacitance diodes will keep the frequency phase-locked to the reference frequencies.

14 Loop Mixer and Phase Detector

In the loop mixer, the signal from the voltage-controlled oscillator is mixed with a harmonic of the 1.4 MHz signal from the master oscillator. The difference frequency is fed through the low-pass filter to the phase detector, which also receives a signal from the channel oscillator.

The phase detector compares the frequencies of the two signals, and when they coincide, 14TR5 will draw current and the collector voltage assume a value which depends on the phase difference between the two signals.

The module contains a switching arrangement which, in the 16, 22 and 25 MHz bands, feeds the channel oscillator signal into the amplifier stage associated with the phase detector, and in the other bands, to the 1st mixer via the switch on module No. 13.

15 Filter for 4.2, 9.8 and 12.6 MHz

The input signal is a 1.4 MHz square-wave signal from the master oscillator. With the "BAND" switch at "16 MHz", the signal is fed by diode switches through the 4.2 MHz band-pass filter, which therefore permits the 3rd harmonic of 1.4 MHz to pass through. On the 22 MHz band, the 7th harmonic is similarly taken out through the 9.8 MHz filter. On the 25 MHz band the 9th harmonic is used which is generated as the 3rd harmonic of 4.2 MHz, the signal from the output of the 4.2 MHz filter being fed to an amplifier and clipper, followed by a band-pass filter at 12.6 MHz.

16 RFI Filters

The RFI filters are inserted in the power supply and control wires to the receiver. They are composed of a number of low-pass filters which suppress noise and interference on these wires.

18 DC Power Pack

Contains fuses, a bypass capacitor, and a 20W 39V Zener diode which protects the receiver against transients on the supply mains and against the consequences of polarity reversal.

19 AC Power Pack

The mains transformer, which is switchable between 110, 220, 380, and 440V, is equipped with a static screen. The bridge rectifier delivers approx. 14V at nominal voltage and load.

3 INSTALLATION

Correct installation of the equipment is important for good results. Aerial and earth connection must be installed with the greatest care, especially where duplex telephony is desired.

3.1. Mounting the Cabinet

The R-0288 cabinet is intended for table-top mounting. It has four vibration dampers which should be secured to the table top as shown in the drawing on page 3-6.

For mounting of the Type TRP 400 see instruction manual for Type T 400 transmitter.

3.2. Disassembling the Receiver

To open the receiver, remove the four front panel screws. Pull the chassis out of the cabinet and remove connectors.

3.3. Connection to the Permanent Installation

Check that the correct power pack is installed in the receiver and that the power pack (if for AC) is set for the correct mains voltage.

Cable connections for the installation of the TRP 400 appear from the drawings on pages 7-77 and 7-76, see instruction manual for Type T 400 transmitter.

Cable connections for installation in a separate cabinet appear from the drawing on page 3-5. The aerial cable should then be connected directly to the aerial plug supplied.

NOTE: Cables should be long enough so that the receiver can be pulled out of the cabinet with the cables connected to it.

3.4. Earth Connection

From a good earth point, run a separate wire of not less than 2.5 sq. mm cross section and as short as possible to the earth contact at the back of the cabinet. The earth lead should not be common to the transmitter and receiver if the receiver is part of a DUPLEX installation.

3.5. Aerial

Length: 6-30 metres. Should be suspended as far from stays and wires as possible and brought in through a length of 50-ohm coaxial cable, which should be as short as possible, especially if the aerial is short.

3.6. Headphones and External Loudspeaker

Headphones should be connected to the audio output via a resistor as shown in the drawing on page 3-5. The resistance value shown provides a convenient level in a 400-ohm telephone cartridge. Other headphone impedances may be used if a series resistor of suitable value is inserted.

An external loudspeaker may be connected to the receiver. Its impedance should be 4 ohms, and it should be able to handle 1W or more. When the loudspeaker is disconnected, a resistor of the same impedance and power rating should be inserted instead. This will ensure that there will be no change in headphone level when the loudspeaker is disconnected.

3.7. Muting in Simplex and Semi-duplex Service

With the "SERVICE" switch at "simplex" or "semi-duplex" the receiver will be muted if multiwire connector terminals 3 and 6 are strapped together.

3.8. Use with Type T 400 Transmitter

When supplied with the Type T 400 transmitter, the receiver carries on its rear wall a BNC connector from which a stable 1.4 MHz signal from the receiver's master oscillator is supplied to the transmitter. The master oscillator can be powered from the transmitter while the receiver is switched off, via terminals 1 and 2 of the receiver multiwire connector. In the TRP 400, all connections between the transmitter and receiver are installed at the factory.

3.9. Replacing the Power Pack

Switching from DC to AC operation is done by replacing the built-in power pack. The power pack becomes accessible after removal of the top cover plate.

IMPORTANT: Switch off the supply voltage - for instance by removing the multiwire plug - before removing the cover plate.

Remove the four screws holding the power pack. The power pack may now be tilted out and released from the cable.

The Type R-0290 DC power pack  is used for 12V or 24V battery operation (no switching).

The Type R-0289 AC power pack  is used when the receiver is to be operated from 110/220/380 or 440V AC. The voltage setting procedure appears from the plate on the power pack or from drawing on page 7-73, which also shows what rating the fuse F1 should have at the supply voltage in question.

NOTE: Check that the power pack is set to the correct voltage and supplied with the correct fuses, before connecting the receiver to the mains.

3.10. Installing Channel Crystals

Channel crystals should meet SKANTI Specification stated in the section Technical Data on the first pages of this manual. Calculation of crystal frequency f_x also appears from Technical Data.

The channel crystals become accessible after removal of the top cover plate. When installing a new crystal, proceed as follows:

- 3.10.1. Locate the crystal socket corresponding to the desired channel number and band, and insert the crystal.
- 3.10.2. Connect a frequency counter (resolution 1 Hz, accuracy 10^{-7}) to the crystal oscillator output, terminals 9-21 and 9-22 (common).
NOTE: In DC operation there may be a voltage difference between common and chassis.
- 3.10.3. Set the "BAND" and "CHANNEL" switches to the new channel and adjust if necessary the trimmer capacitor associated with the crystal position so that the frequency will be that specified on the side of the crystal holder (-0/+5 Hz).
- 3.10.4. Take out the frequency chart on the front panel by tilting the Plexiglas plate out. Note the new receiver frequency - listed on the top of the crystal holder - in the frequency chart.
For HF channels: Put an "S" before the frequency if it is in the simplex band, and a "D" if it is in the duplex band.

For coastal telephony channels: Remove the aerial plug. Turn the "CT PRESELECTOR" to its fully anticlockwise position. Set "RF GAIN" to "AGC" and the "MODE" switch to "A3J, A3A". Set "AF GAIN" for convenient noise level. Now turn the "CT PRESELECTOR" clockwise and note when the noise level begins to increase. Adjust for maximum noise at the first noise peak. Read the nearest division line on the scale and note that figure in the space marked "PS" in the frequency chart, at the channel in question.

		Frequency Range, kHz	
Band	Service	Simplex	Semi-duplex/duplex
CT		1605-4000	
4 MHz		4139.5	4361.6 - 4434.9
6 MHz		6210.4 - 6213.5	6515.4 - 6521.8
8 MHz		8281.2 - 8284.4	8729 - 8812
12 MHz		12421 - 12428	13109 - 13196.5
16 MHz		16565 - 16572	17255 - 17356.5
22 MHz		22094.5 - 22108.5	22625.5 - 22716.5
25 MHz		25010 - 25180	25300 - 25600

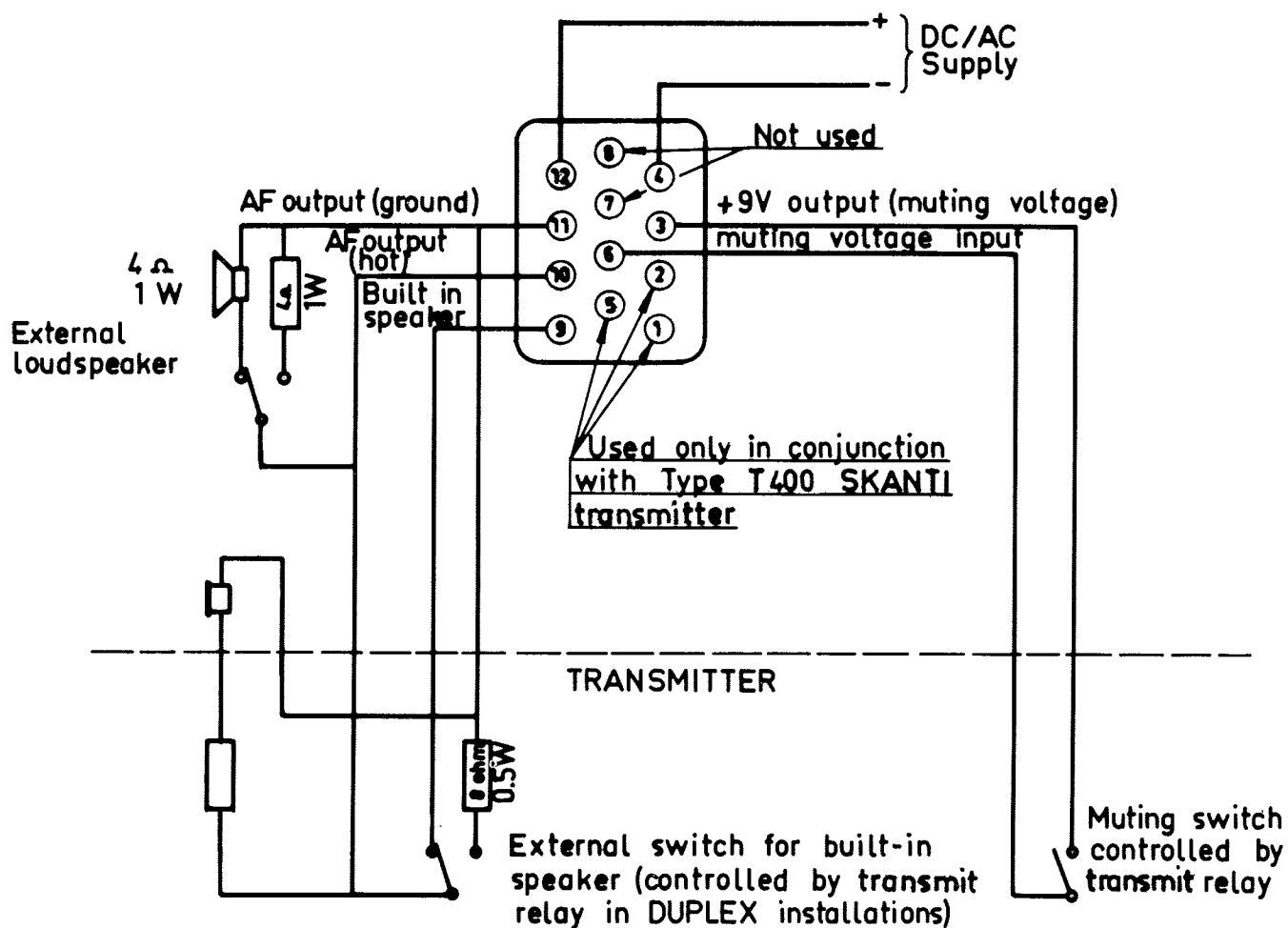
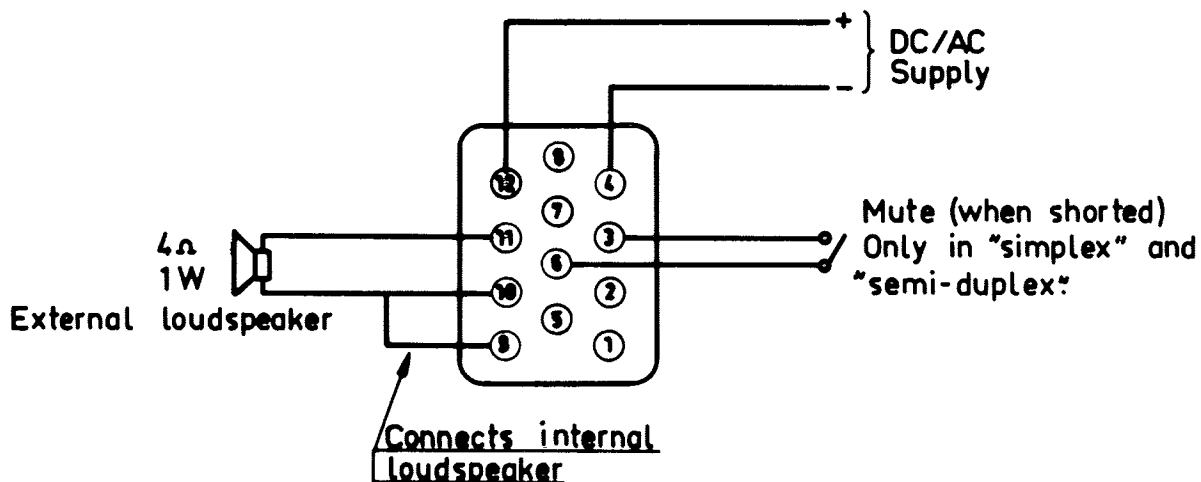

Vægt: 15,4 Kg
Weight: 15.4 Kg

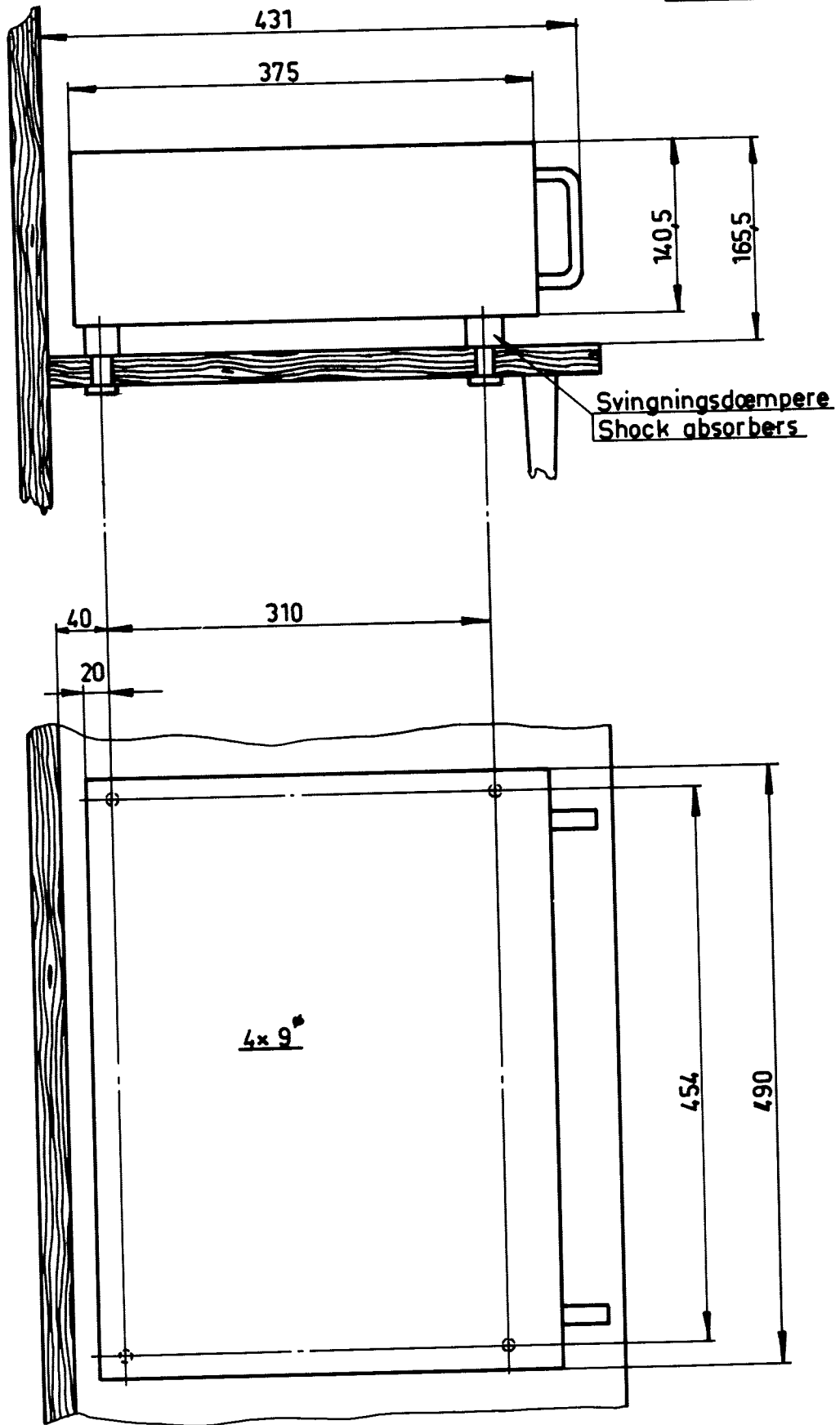

Tolerances: ± 0.5mm Dimensions are in mm.

4. OPERATING INSTRUCTIONS

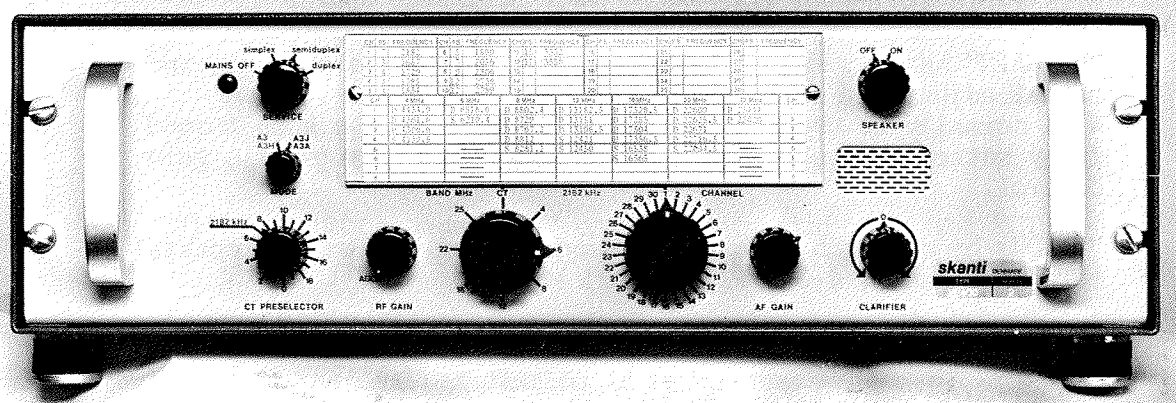

Fig. 4.1. Front panel and operating controls.

4.1. Operating Controls and Their Functions

The "SERVICE" switch has four positions:

"MAINS OFF" - receiver is switched off.

"simplex" - for simplex service.

The receiver is muted when transmitting. On the HF bands, the simplex filters are in operation.

"semi-duplex" - for semi-duplex service.

The receiver is muted when transmitting. On the HF bands, the duplex filters are in operation.

"duplex" - for duplex service.

The receiver is in operation while transmitting. The built-in speaker is disconnected when the transmitter starts up, leaving only the headphones connected to the receiver output. On the HF bands, the duplex filters are in operation.

The "MODE" switch has two positions.

"A3, A3H" - for reception of double and single sideband modulation with full carrier.

"A3J, A3A" - for reception of single sideband modulation with suppressed or reduced carrier.

"CT PRESELECTOR" - for tuning the front end circuits in the coastal telephony band. Approximate settings are indicated on the frequency chart on the front panel. Adjust for maximum volume around the setting indicated. An indexed position permits rapid tuning to 2182 kHz.

"RF GAIN" has two functions: switching the AGC in and out, and manual adjustment of RF gain. Will normally be used in the AGC setting, with the knob turned fully anticlockwise, where a switch cuts in the automatic gain control.

"BAND", band switch with the following 8 positions: CT (coastal telephony band), 4-6-8-12-16-22-25 MHz.

"CHANNEL", channel selector with 30 positions.

"AF GAIN" - audio volume control.

"CLARIFIER" - for accurate tuning to frequency. Adjust for natural-sounding speech. For use in "A3J, A3A" mode only.

"SPEAKER" - switch which disconnects the built-in loudspeaker.

4.2. Tuning to 2182 kHz

Set:

- (1) "SERVICE" switch to "simplex", "semi-duplex" or "duplex". Pilot lamp will come on.
- (2) "MODE" switch to "A3, A3H".
- (3) "CT PRESELECTOR" to indexed position at 2182 kHz marking.
- (4) "RF GAIN" to "AGC".
- (5) "BAND" switch to "CT".
- (6) "CHANNEL" switch to "1".
- (7) "SPEAKER" switch to "ON".
- (8) "AF GAIN" for convenient volume.

4.3. Tuning to SSB Station in Coastal Telephony Band

- (1) Set "SERVICE" switch to the desired service, "simplex", "semi-duplex" or "duplex". Pilot lamp will come on.
- (2) Set "MODE" switch to "A3J, A3A".
- (3) Set "RF GAIN" to "AGC".

- (4) Set "SPEAKER" switch to "ON".
- (5) Set "AF GAIN" for convenient volume.
- (6) Set "BAND" switch to "CT".
- (7) Select desired frequency on frequency chart.
- (8) Read channel number under "CH" on frequency chart and set "CHANNEL" switch to that number.
- (9) Read number under "PS" on frequency chart and set "CT PRESELECTOR" for maximum level near division line in question.
- (10) Adjust "CLARIFIER" control for natural-sounding speech when the desired station is modulated.

4.4. Tuning to SSB Station in HF Band

- (1) Set "SERVICE" switch to the desired service, "simplex", "semi-duplex" or "duplex".
- (2) Set "MODE" switch to "A3J, A3A".
- (3) Set "RF GAIN" to "AGC".
- (4) Set "BAND" switch to desired HF band.
- (5) Select desired frequency on frequency chart.
- (6) Read channel number under "CH" on frequency chart and set "CHANNEL" switch to that number.

An S or a D before the HF frequencies on the chart indicates whether the frequency in question is in the simplex or duplex frequency range.

For S, the "SERVICE" switch should be at "simplex".

For D, the "SERVICE" switch should be at "semi-duplex" or "duplex".

- (7) Set "SPEAKER" switch to "ON".
- (8) Set "AF GAIN" for convenient volume.
- (9) Adjust "CLARIFIER" control for natural-sounding speech when the desired station is modulated.

5. SIMPLE SERVICE

5.1. Incorrect Operation

If the receiver is not functioning normally a check should be made whether it is being operated correctly. It is suggested that adjustment procedures 4.2, 4.3 or 4.4 are performed.

5.2. Pilot Lamp Replacement

The pilot lamp may be replaced without opening the receiver. The lamp is defective if it shows no light and the receiver is functioning normally. Unscrew the lamp cover; this will cause the lamp to come out, and a new lamp may be inserted.

5.3. Fuse Replacement

If the pilot lamp does not come on when the receiver is switched on, and if the receiver is dead, the two fuses should be checked. These become accessible when the receiver is opened by removing the four front-panel screws and the chassis is pulled approx. 15 cm out of the cabinet.

For DC operation from 12V or 24V battery, the fuses should be rated at 1.6A, quick-acting.

For AC operation, the fuse nearest the front panel should likewise be 1.6A, quick-acting, whereas the rating of the other fuse depends on the mains voltage as follows:

110V:	315mA, slow-acting
220V:	160mA, slow-acting
380V:	80mA, slow-acting
440V:	80mA, slow-acting

Do not use fuses whose rated values exceed the values specified.

6. REPAIR AND ALIGNMENT

6.1. Introduction

Repairs and adjustments on the receiver should be performed only by qualified technicians, to whom this chapter is addressed. Before attempting any repairs or adjustments, a study of Chapter 2, Technical Description, is recommended.

6.2. Cross-slot Screws

The cross-slot screws used are Pozidriv screws. A Pozidriv screwdriver no. 1 should be used in order to avoid damaging such screws.

6.3. Locating Subunits and Components

Locations of circuit boards in the receiver appear from the four drawings, pages 7-31 to 7-34. Locations of components on each circuit board appear from the component location drawings against the respective circuit diagrams.

6.4. Locating Faults

Fault finding, as described in section 6.5. below, is aided by test points provided for the purpose of permitting rapid localization of faulty circuit boards on the basis of DC measurements. Since not all types of faults can be traced by means of DC measurements, supplementary AC measurements with an RF millivoltmeter may be required; see section 6.6. To facilitate fault finding on each individual circuit board, typical DC voltages are shown on the circuit diagrams; see section 6.7. Lastly, to facilitate fault finding in the signal path, section 6.8. includes tables listing typical sensitivities.

6.5. Test Points

Most circuit boards contain one or more test points that permit checking the active elements on each board. They are small pin-type terminals, ring colour coded following the standard colour code in addition to being numbered. In the circuit diagrams, test points are marked TP 1, TP 2 etc., and typical DC voltages at the test points are listed there. Voltages listed are based on measurement with a multimeter having a sensitivity of 25 kohms/volt. If a voltage measured at a test point differs markedly from the listed value it is a fairly certain indication that the circuit board in question is faulty, assuming that the DC voltages applied to the circuit board are the correct ones. This should be checked.

6.6. AC Voltages

In the circuit diagrams, typical AC voltages are listed at all relevant terminals. Voltages listed are injection signals which are generated in the receiver and therefore independent of whether the receiver is processing an incoming signal or not. Values listed are based on measurement with an RF millivoltmeter having an input impedance of 20 kohms in parallel with 5 pF, a sensitivity of the order of 10mV f.s.d. and a frequency range of not less than 0.5 - 30 MHz.

6.7. DC Voltages

Typical DC voltages listed in the circuit diagrams are based on measurement with a 25 kohms/volt multimeter. If a stated voltage is dependent on the setting of a control, the position of the control in question is stated in brackets after the voltage designation.

6.8. Typical Sensitivities

The following two Tables list sensitivity levels at various points of the signal path. Requisite measuring equipment is a multimeter, an AF voltmeter, a tone generator and a signal generator covering the frequency range 0.5 - 30 MHz.

Typical Input Voltages for 2V AF Output Voltage

Input Terminal	'MODE' switch	Generator Frequency	Signal Generator AM	Typical Sensitivity
7-2	-	1000 Hz	-	20mV
6-2	A3J	1399 kHz	0	62 dB/1uV
6-2	A3	1400 kHz	30%, 1000 Hz	72 dB/1uV

The Table above lists typical values of input voltages which must be applied to the AF amplifier and detector to obtain an output voltage of $2V_{rms}$, 1000 Hz, measured across AF output terminals 110 and 111 with a 4-ohm load connected across the latter. Set "RF GAIN" for minimum gain and "AF GAIN" for maximum gain. Measure input voltage at terminal 7-2 with an AF millivoltmeter. The signal generator used for checking the sensitivity at terminal 6-2 should have a low output impedance (10 ohms) and be connected through a 0.1 uF DC blocking capacitor; the input voltage can then be read on the signal generator.

Typical Input Voltages for 1.6V AGC Voltage

Input Terminal	'MODE' Switch	'BAND' Switch	Generator Frequency	Generator Amplitude Modulation	Generator Output Impedance	Typical Sensitivity (dB/1uV)
6-2	A3J	-	1399 kHz	0	10 ohms + 0.1 uF	70
6-2	A3	-	1400 kHz	30%, 1000Hz	10 ohms + 0.1 uF	74
5-1	A3J	CT or 4 MHz	499 kHz	0	10 ohms + 0.1 uF	26
5-1	A3	CT or 4 MHz	500 kHz	30%, 1000Hz	10 ohms + 0.1 uF	36
5-1	A3J	6-25 MHz	10701 kHz	0	10 ohms + 0.1 uF	22
4-1	A3J	CT (Channel 1)	2183 kHz	0	10 ohms + 0.1 uF	20
4-1	A3J	6-25 MHz	Selected channel freq.+1kHz	0	10 ohms + 0.1 uF	22
Aerial Socket	A3J	CT (Channel 1)	2183 kHz	0	10 ohms + 250 pF	10
Aerial Socket	A3J	4-25 MHz	Selected channel freq.+1kHz	0	50 ohms	8

The table above states typical values of input voltage to be applied to each

module in the signal path for AGC voltage of 1.6V measured with 25 kohms/V DC voltmeter between terminals 6-9 and 6-10.

"RF GAIN" should be set to "AGC" and "AF GAIN" adjusted for convenient volume level.

It should be kept in mind that voltages listed are typical values and that any deviations from them are not necessarily an indication of faults.

6.9. Adjustments

This section describes alignment procedures for each individual module (subunit) that contains adjustable components. Keep in mind that alignment should not be carried out unless there is a clear indication that it is really necessary; moreover, alignment should be carried out only by a qualified technician with the necessary equipment at his disposal.

2 Realignment of CT FRONT END

Measuring equipment:

Standard signal generator covering the range 1.6 - 4 MHz and having an output impedance of 10 ohms in series with 250 pF.

RF millivoltmeter having a sensitivity of 10mV f.s.d. Input impedance better than 10 kohms in parallel with 6 pF.

Receiver settings:

SERVICE: simplex, semi-duplex, or duplex

RF GAIN: max.

BAND: CT

CHANNEL: to any vacant crystal position.

- (1) Turn "CT PRESELECTOR" fully anticlockwise and check that arrow points to "0".
- (2) Connect signal generator to aerial input socket and RF millivoltmeter between terminals 2-2 and 2-1.
- (3) Set signal generator to 1820 kHz and 10mV (e.m.f.) and "CT PRESELECTOR" to "4".
- (4) Connect a 10-kohm damping resistor across middle section of tuning capacitor and adjust cores of 2T1 and 2T3 for maximum output voltage.
- (5) Transfer damping resistor to foremost capacitor section and adjust core of 2T2 for maximum output voltage.
- (6) Set signal generator to 3800 kHz and "CT PRESELECTOR" to "18".
- (7) Adjust trimmer 2C7 for maximum output voltage.

(8) Transfer damping resistor to middle capacitor section and adjust trimmers 2C5 and 2C13 for maximum output voltage.

(9) Repeat items (3) to (8).

With these adjustments completed, output voltage should be approx. 50mV.

Adjustment of the 2182-kHz indexed setting should be carried out with the receiver and signal generator set to 2182 kHz. Loosen the Allen screws in the indexing wheel and adjust "CT PRESELECTOR" for max. output signal. Turn the wheel until the ball falls into the notch. Thereafter tighten the Allen screws.

3 Realignment of HF COIL SECTION

Measuring equipment:

Standard signal generator covering the range 4 - 30 MHz and having an output impedance of 50 ohms. Accuracy better than 10 kHz.

RF millivoltmeter having a sensitivity of 10mV f.s.d. Input impedance better than 10 kohms in parallel with 6 pF.

Receiver settings:

BAND and SERVICE: Band to be aligned.

RF GAIN: max.

CHANNEL: to any vacant crystal position, e.g. Channel 9.

AF GAIN: min.

Input filters:

- (1) Connect RF millivoltmeter probe directly to input terminals of filter to be aligned.
- (2) Connect signal generator to aerial input socket and set it to alignment frequency indicated in Table below. Output voltage: 10mV - 100mV.
- (3) Detune second - in case of a duplex filter also third - tuned circuit of filter to be aligned by turning core outwards.
- (4) Adjust first tuned circuit for maximum voltage as indicated by RF millivoltmeter. Adjust second circuit for minimum reading and - in case of a duplex filter - third tuned circuit for maximum.

Intermediate tuned circuits:

- (1) Connect RF millivoltmeter between output terminals 3-18 and 3-17.
- (2) Set signal generator to alignment frequency indicated in Table below.

- (3) Adjust intermediate tuned circuit in question for maximum or minimum reading as indicated in Table. Alignment frequencies are outside the simplex and duplex bands and signal generator output voltage may have to be increased to compensate for input filter attenuation.

ALIGNMENT FREQUENCIES				
BAND	INPUT FILTERS		INTERMEDIATE TUNED CIRCUITS	
	Simplex	Duplex	Freq.	tune to
4 MHz	4 140 kHz	4 400 kHz	4 300 kHz	max.
6 MHz	6 210 kHz	6 550 kHz	6 370 kHz	max.
8 MHz	8 280 kHz	8 770 kHz	8 540 kHz	max.
12 MHz	12 420 kHz	13 180 kHz	12 800 kHz	max.
16 MHz	16 570 kHz	17 360 kHz	18 640 kHz	min.
22 MHz	22 090 kHz	22 800 kHz	23 500 kHz	min.
25 MHz	25 080 kHz	25 470 kHz	25 300 kHz	max.

4 Realignment of 1st MIXER

Measuring equipment:

Standard signal generator covering the range 0.5 - 12 MHz.

RF millivoltmeter having a sensitivity of 10mV f.s.d. Input impedance better than 10 kohms in parallel with 6 pF.

Frequency counter having an accuracy better than 10^{-6} .

Realignment of 500 kHz trap:

- (1) Set receiver to "CT" or "4MHz" band, "RF GAIN" to max. gain, "MODE" to "A3J".
- (2) Connect signal generator to aerial input socket and set it to 499 kHz and an output level that will allow signal to be heard in receiver.
- (3) Adjust core of 4L3 for min. output signal.

Realignment of 11.74 MHz trap:

The purpose of the trap is to suppress a spurious signal that may occur in the 12-MHz band.

- (1) Set signal generator to a channel in 12 MHz simplex band.
- (2) Connect signal generator to aerial input socket and set it to output voltage of approx. 10mV. Search for spurious signal by varying signal-generator frequency around 11.7 MHz.
- (3) Adjust core of 4L2 for min. output signal.

Realignment of 500-kHz band-pass filter:

- (1) Set receiver to 2182 kHz. "RF GAIN" at max.
- (2) Connect frequency counter to channel oscillator output. Check crystal frequency. In case of difference greater than 10 Hz adjust to correct frequency by means of crystal trimmer capacitor.
- (3) Connect counter to signal generator. Set signal generator to 2182.4 kHz.
- (4) Connect RF millivoltmeter to hot end of 4L6 and vary signal-generator output voltage until millivoltmeter reads approx. 10mV.
- (5) Short-circuit capacitor 4C14 and adjust core of 4L6 for maximum millivoltmeter reading.
- (6) Transfer short-circuit to 4C16 and adjust 4L8 for minimum millivoltmeter reading.
- (7) Transfer short-circuit to 4C19 and adjust 4L9 for maximum reading.
- (8) Remove short-circuit and adjust 4L10 for minimum reading.

After adjustment, the 3-dB band limits as measured with the RF millivoltmeter at output terminals 4-8 and 4-7 should be below and above 2178.3 kHz and 2186.5 kHz, respectively.

8 Adjustment of 9V Voltage Regulator

Measuring equipment: DC voltmeter having an accuracy of 1.5% or better.

- (1) Set receiver to "CT" band.
- (2) Connect voltmeter between terminals 8-5 and 8-7.
- (3) Check that voltage is between 8.9V and 9.1V. If this is not the case adjust alignment potentiometer 8R8 (red) for correct voltage.
- (4) To check the current-limiting function, connect briefly a 2.2-ohm resistor between output terminals 8-5 and 8-7. The current limiter should cut out instantly; that is, the 9V supply should go dead, following which the receiver is turned off with the "SERVICE" switch and turned on again after approx. 3 seconds. If the current limiter does not cut out, turn 8R6 (yellow) slightly clockwise and repeat the check.
- (5) Thereafter similarly connect a 3.3-ohm resistor briefly across the output terminals; now the current limiter should not cut out. If this happens, the potentiometer 8R6 (yellow) will have been turned too far clockwise and must be backed off slightly, following which items (4) and (5) are repeated.

10 Realignment of CLARIFIER OSCILLATOR

Measuring equipment:

Frequency counter having an accuracy better than 10^{-6} and a sensitivity of at least 20mV.

- (1) Connect counter between terminals 10-2 and 10-3.
- (2) With the "CLARIFIER" control in the "0" position the frequency should be 900,000 Hz \pm 20 Hz. In the extreme positions, the frequency should be less than 899,800 Hz and more than 900,200 Hz, respectively.
- (3) Adjustment of the centre frequency may be carried out with the core of 10L1. The oscillator must be taken out of the receiver and the cover removed. Place the shaft in the mid-travel position and reconnect the wires to the receiver.
- (4) With a screwdriver through the hole in the rear wall adjust the core until the frequency is correct with the cover in place. After adjustment lock the core to the movable arm with wax.

12 Realignment of 12.1 MHz MIXER

Measuring equipment:

RF millivoltmeter having a sensitivity of 10mV f.s.d.

- (1) Connect RF millivoltmeter between terminals 12-4 and 12-5.
- (2) Set receiver "BAND" switch to any one of the 6- to 25-MHz bands.
- (3) Adjust core of 12L1 for maximum output voltage.

13 Realignment of VOLTAGE CONTROLLED OSCILLATOR

Measuring equipment:

Frequency counter having a sensitivity of 100mV and an accuracy of 10^{-4} or better.

Variable power supply: 1V - 20V.

As described in section 2.4 where this module is mentioned, the frequency of the oscillator is primarily determined by:

- (1) The "BAND" switch setting
- (2) The state of the binary 16-counter
- (3) The voltage controlling the variable capacitance diodes.

An adjustable coil is provided for each band - in the case of the 16 MHz band, 13L8. For the 22 MHz and 25 MHz bands this coil is in parallel with 13L4 and 13L7, respectively. Adjustment of 13L28 thus affects the frequency alignment on the other two bands, and this coil is therefore to be realigned first, followed by realignment of 13L4 and 13L7.

Realignment is to be carried out with a certain amount of control voltage (1V) applied to the variable capacitance diodes and the counter in a certain state (all capacitors fully meshed). The following procedure may be employed:

- (1) Connect counter between terminals 13-4 and 13-3 and set it to 0.1 msec gate-time (10-kHz resolution).
- (2) Unsolder wire from terminal 13-7 and connect 1 Mohm resistor instead. Connect variable power supply between this resistor and common.
- (3) Set "BAND" switch to 16 MHz and the variable power supply to deliver approx. 20V.
- (4) The hunting-oscillator will now step the counter forward at the rate of approx. 1 step per second. By briefly connecting the variable power supply to the 1 Mohm resistor the counter can be stepped forward, one step at a time, and in this way the setting giving the lowest output frequency is found. When this setting has been reached, adjust the power supply to deliver 1V and connect it to the 1Mohm resistor.
- (5) Check the correctness of the resulting counter setting by measuring the input voltages fed to IC 1 at pins 1, 4, 9 and 12. All voltages should be high, i.e. approx. +3.5V DC.

NOTE: If the receiver is switched off or the "BAND" switch setting is altered, the counter state will change, and the procedure described above must therefore be repeated.

- (6) Set counter to 1-kHz resolution and adjust frequency to 5800 kHz with core of 13L8.
- (7) Repeat the procedure in the 22 MHz and 25 MHz bands. Adjust 13L4 and 13L7 to 11,200 kHz and 14,400 kHz respectively.

14 Realignment of LOOP MIXER and PHASE DETECTOR

Measuring equipment:

Standard signal generator covering 14 MHz and having an output impedance of 50 ohms.

RF millivoltmeter having a sensitivity of 10mV f.s.d. Input impedance better than 10 kohms in parallel with 6 pF.

- (1) Unsolder coaxial cable from terminal 14-8 and connect signal generator instead.
- (2) Set "BAND" switch to 22 MHz.
- (3) Set signal generator to 14.0 MHz \pm 10 kHz and 160mV. The difference frequency at the output of loop mixer IC 1 will then be 4.2 MHz.
- (4) Connect RF millivoltmeter to collector of 14TR3 and adjust 14L3 for minimum meter reading.

15 Realignment of Filters for 4.2, 9.8 and 12.6 MHz

Measuring equipment:

RF millivoltmeter having a sensitivity of 10mV f.s.d. Input impedance better than 10 kohms in parallel with 6 pF.

- (1) Connect RF millivoltmeter between terminals 15-7 and 15-8.
- (2) Set "BAND" switch to 16 MHz and adjust 15L1 and 15L3 for max. output voltage.
- (3) Set "BAND" switch to 22 MHz and adjust 15L2 and 15L4 for max. output voltage.
- (4) Set "BAND" switch to 25 MHz and adjust 15L5 and 15L6 for max. output voltage.

7. PARTS LISTS AND CIRCUIT DIAGRAMS

7.1. Numbering

An identification number between $\triangle 2$ and $\triangle 19$ is assigned to each module. The designation of a component or terminal includes this number as a prefix - example: 5R23 (resistor R23 on module $\triangle 5$) or 6-5 (terminal No. 5 on module $\triangle 6$). Components that do not belong to any module (chassis-mounted components) carry the prefix 17.

7.2. Switches

Switches with stops are shown in the extreme anticlockwise position. The "BAND" and "CHANNEL" switches are shown in the "CT" and "CHANNEL 1" positions, respectively. Switch wafer No.1 is the wafer nearest the front panel, and the front side of a wafer is the side facing the front panel.

7.3. Terminals

Locations of terminals appear from the component location drawings and from the circuit-board location plans. On the vertical circuit boards, terminal numbers always start in the top left-hand corner, reading from left to right with the receiver placed in its normal position. Terminals are identified by their numbers in the circuit diagrams (example: 14-2) and, in most cases, by explanatory texts. Interconnections between modules are additionally identified by the numbers of the module and terminal to which the lead connects (example: $\triangle 13$ -7). For coaxial cables, only the number of the terminal is given to which the inner conductor is connected.

7.4. Voltages

Typical DC voltages are indicated in the circuit diagrams next to the points to which they refer. Typical AC voltages are indicated at certain terminals and are given as RMS values. For measuring conditions see Chapter 6.

7.5. Test Points

Locations of test points appear from the component-location drawings and from the circuit-board location plans. Typical DC voltages at test points are listed in the circuit diagrams.

ABBREVIATIONS

A	= ampere, amperes	PL	= connector (plug)
C	= capacitor	polyes.	= polyester
Car.	= carbon	polyst.	= polystyrene
Cer.	= ceramic	PTC	= pos. temp. coefficient
D	= diode	R	= resistor
F	= farad	RL	= relay
FS	= fuse	S	= switch
H	= henry	SK	= connector (socket)
IC	= integrated circuit	SL	= lamp
k	= kilo or 10^3	T	= transformer
L	= inductor	Tan	= tantalum electrolytic capacitor
lin.	= linear	TR	= transistor
log.	= logarithmic	V	= working voltage DC
m	= milli or 10^{-3}	V1...	= valve
M	= mega or 10^6	Vac.	= working voltage AC
Mi	= mica	Var.	= variable
MP	= metallized paper	Varicap	= variable capacitance diode
μ	= micro or 10^{-6}	ww	= wire wound
n	= nano or 10^{-9}	W	= watt, watts
NTC	= neg. temp. coefficient	W.alum.	= wet aluminium electrolytic
p	= pico or 10^{-12}	X	= crystal, crystal osc. or crystal filter

PARTS LIST
FOR
CT FRONT END



2C 1- 2	0.1 μ F	10%	250V	Polyes.
2C 3	2.2 pF	0.25pF	400V	Cer.NP0
2C 4	39 pF	5%	400V	Cer.N150
2C 5	20 pF	Var.		Cer.
2C 6	3x518 pF	Var.	L.3G3.S	Air.
2C 7	20 pF	Var.		Cer.
2C 8	47 pF	5%	400V	Cer.N150
2C 9	47 nF	-20/+80%	12V	Cer.
2C10-11	0.1 μ F	-20/+80%	12V	Cer.
2C12	47 pF	5%	400V	Cer.N150
2C13	20 pF	Var		Cer.
2C14	0.1 μ F	-20/+80%	12V	Cer.
2D 1- 2	1S920			
2D 3	BZX79 C6V8	Zener		
2IC 1	SL610C			
2L 1	COIL		SKANTI CODE: R-0240	
2R 1	2.2 kohms	5%	1/8W	Car.
2R 2	47 ohms	5%	1/8W	Car.
2R 3	100 ohms	5%	1/8W	Car.
2R 4	68 ohms	5%	1/8W	Car.
2T 1	TRANSFORMER		SKANTI CODE: R-0237	
2T 2	TRANSFORMER		SKANTI CODE: R-0238	
2T 3	TRANSFORMER		SKANTI CODE: R-0239	
2SL 1	LAMP	A9A-C		

PARTS LIST
FOR
HF COIL SECTION



3C 1	0.1 μ F	10%	250V	Polyes.
3C 2	47 nF	-20/+80%	12V	Cer.
3C 3	27 pF	5%	400V	Cer.N150
3C 4-10	0.1 μ F	10%	250V	Polyes.
3C11	47 nF	-20/+80%	12V	Cer.
3C12	15 pF	5%	400V	Cer.N150
3C13	160 pF	5%	400V	Cer.N150
3C14	130 pF	5%	400V	Cer.N150
3C15	100 pF	5%	400V	Cer.N150
3C16	91 pF	5%	400V	Cer.N150
3C17	68 pF	5%	400V	Cer.N150
3C18	51 pF	5%	400V	Cer.N150
3C19	39 pF	5%	400V	Cer.N150
3C20	47 nF	-20/+80%	12V	Cer.
3C21	6.8 pF	± 0.25 pF	400V	Cer.N150
3C22	4.7 pF	± 0.25 pF	400V	Cer.N150
3C23-24	3.9 pF	± 0.25 pF	400V	Cer.N150
3C25-26	2.7 pF	± 0.25 pF	400V	Cer.NP0
3C27	2.2 pF	± 0.25 pF	400V	Cer.NP0
3C28	12 pF	5%	400V	Cer.N150
3C29	5.6 pF	± 0.25 pF	400V	Cer.N150
3C30	3.9 pF	± 0.25 pF	400V	Cer.N150
3C31	3.3 pF	± 0.25 pF	400V	Cer.N150
3C32	3.9 pF	± 0.25 pF	400V	Cer.N150
3C33	2.7 pF	± 0.25 pF	400V	Cer.NP0
3C34-35	2.2 pF	± 0.25 pF	400V	Cer.NP0
3C36	47 nF	-20/+80%	12V	Cer.
3C37	160 pF	5%	400V	Cer.N150
3C38	130 pF	5%	400V	Cer.N150
3C39	100 pF	5%	400V	Cer.N150
3C40	91 pF	5%	400V	Cer.N150
3C41	68 pF	5%	400V	Cer.N150
3C42	51 pF	5%	400V	Cer.N150
3C43	39 pF	5%	400V	Cer.N150
3C44	8.2 pF	± 0.25 pF	400V	Cer.N150
3C45	47 nF	-20/+80%	12V	Cer.
3C46	6.8 pF	± 0.25 pF	400V	Cer.N150
3C47	4.7 pF	± 0.25 pF	400V	Cer.N150
3C48-49	3.9 pF	± 0.25 pF	400V	Cer.N150
3C50-51	2.7 pF	± 0.25 pF	400V	Cer.NP0
3C52	2.2 pF	± 0.25 pF	400V	Cer.NP0
3C53	5.6 pF	± 0.25 pF	400V	Cer.N150
3C54	3.9 pF	± 0.25 pF	400V	Cer.N150
3C55-56	3.3 pF	± 0.25 pF	400V	Cer.N150
3C57	2.7 pF	± 0.25 pF	400V	Cer.NP0
3C58-59	2.2 pF	± 0.25 pF	400V	Cer.NP0
3C60	33 pF	5%	400V	Cer.
3C61	160 pF	5%	400V	Cer.N150
3C62	130 pF	5%	400V	Cer.N150
3C63	100 pF	5%	400V	Cer.N150



3C64	91 pF	5%	400V	Cer.N150
3C65	68 pF	5%	400V	Cer.N150
3C66	51 pF	5%	400V	Cer.N150
3C67	39 pF	5%	400V	Cer.N150
3C68	150 pF	5%	400V	Cer.N150
3C69	47 nF	-20/+80%	12V	Cer.
3C70	12 pF	5%	400V	Cer.N150
3C71	100 pF	5%	400V	Cer.N150
3C72-79	47 nF	-20/+80%	12V	Cer.
3C80	4.7 pF	±0.25pF	400V	Cer.N150
3C81-87	47 nF	-20/+80%	12V	Cer.
3C88	4.7 nF	-20/+80%	30V	Cer.
3C89	180 pF	5%	400V	Cer.N150
3C90	150 pF	5%	400V	Cer.N150
3C91	110 pF	5%	400V	Cer.N150
3C92	100 pF	5%	400V	Cer.N150
3C93	75 pF	5%	400V	Cer.N150
3C94	56 pF	5%	400V	Cer.N150
3C95	39 pF	5%	400V	Cer.N150
3C96	5.6 pF	±0.25pF	400V	Cer.N150
3C97-98	3.3 pF	±0.25pF	400V	Cer.N150
3C99	2.7 pF	±0.25pF	400V	Cer.NP0
3C100-101	2.2 pF	±0.25pF	400V	Cer.NP0
3C102	1.8 pF	±0.25pF	400V	Cer.NP0
3C103	5.6 pF	±0.25pF	400V	Cer.N150
3C104	3.9 pF	±0.25pF	400V	Cer.N150
3C105	3.3 pF	±0.25pF	400V	Cer.N150
3C106	2.7 pF	±0.25pF	400V	Cer.NP0
3C107-108	2.2 pF	±0.25pF	400V	Cer.NP0
3C109	1.8 pF	±0.25pF	400V	Cer.NP0
3C110	47 nF	-20/+80%	12V	Cer.
3C111	180 pF	5%	400V	Cer.N150
3C112	150 pF	5%	400V	Cer.N150
3C113	110 pF	5%	400V	Cer.N150
3C114	100 pF	5%	400V	Cer.N150
3C115	75 pF	5%	400V	Cer.N150
3C116	56 pF	5%	400V	Cer.N150
3C117	39 pF	5%	400V	Cer.N150
3C118	47 nF	-20/+80%	12V	Cer.
3C119-125	0.1 μF	10%	250V	Polyes.
3C126	47 nF	-20/+80%	12V	Cer.
3D 1-24	1S920			
3D25	BZX79 C6V8	Zener		
3IC 1	S1610C			
3L 1	COIL		SKANTI CODE: R-0204	
3L 2	COIL		SKANTI CODE: R-0205	
3L 3	COIL		SKANTI CODE: R-0206	
3L 4	COIL		SKANTI CODE: R-0207	
3L 5	COIL		SKANTI CODE: R-0182	



3L 6	COIL			SKANTI CODE: R-0183
3L 7	COIL			SKANTI CODE: R-0184
3L 8	COIL			SKANTI CODE: R-0185
3L 9	COIL			SKANTI CODE: R-0186
3L10-11	COIL			SKANTI CODE: R-0187
3L12-13	COIL			SKANTI CODE: R-0208
3L14	COIL			SKANTI CODE: R-0209
3L15-16	1 mH	RF CHOKE		10%

3R 1- 7	1.0 kohm	5%	1/8W	Car.
3R 8-11	150 ohms	5%	1/8W	Car.
3R12-18	1.0 kohm	5%	1/8W	Car.
3R19	150 ohms	5%	1/8W	Car.
3R20	330 ohms	5%	1/8W	Car.
3R21	150 ohms	5%	1/8W	Car.
3R22-28	1.0 kohm	5%	1/8W	Car.
3R29	1.8 kohms	5%	1/8W	Car.
3R30-36	1.0 kohm	5%	1/8W	Car.
3R37	47 ohms	5%	1/8W	Car.
3R38	100 ohms	5%	1/8W	Car.
3R39	33 ohms	5%	1/8W	Car.

3SL 1- 7	LAMP	A9A-C		
----------	------	-------	--	--

3T 1	TRANSFORMER			SKANTI CODE: R-0176
3T 2	TRANSFORMER			SKANTI CODE: R-0177
3T 3	TRANSFORMER			SKANTI CODE: R-0178
3T 4	TRANSFORMER			SKANTI CODE: R-0179
3T 5	TRANSFORMER			SKANTI CODE: R-0180
3T 6- 7	TRANSFORMER			SKANTI CODE: R-0181
3T 8	TRANSFORMER			SKANTI CODE: R-0188
3T 9	TRANSFORMER			SKANTI CODE: R-0189
3T10	TRANSFORMER			SKANTI CODE: R-0190
3T11	TRANSFORMER			SKANTI CODE: R-0191
3T12	TRANSFORMER			SKANTI CODE: R-0192
3T13-14	TRANSFORMER			SKANTI CODE: R-0193
3T15	TRANSFORMER			SKANTI CODE: R-0200
3T16	TRANSFORMER			SKANTI CODE: R-0201
3T17	TRANSFORMER			SKANTI CODE: R-0202
3T18	TRANSFORMER			SKANTI CODE: R-0191
3T19	TRANSFORMER			SKANTI CODE: R-0192
3T20-21	TRANSFORMER			SKANTI CODE: R-0203
3T22	TRANSFORMER			SKANTI CODE: R-0194
3T23	TRANSFORMER			SKANTI CODE: R-0195
3T24	TRANSFORMER			SKANTI CODE: R-0196
3T25	TRANSFORMER			SKANTI CODE: R-0197
3T26	TRANSFORMER			SKANTI CODE: R-0198
3T27-28	TRANSFORMER			SKANTI CODE: R-0199

PARTS LIST

FOR

1. MIXER



4C 1	8.2 pF	±0.25pF	400V	Cer.N150
4C 2	12 pF	±5%	400V	Cer.N150
4C 3	2.2 nF	±1%	125V	Polyst.
4C 4	22 nF	-20/+80%	30V	Cer.
4C 5	22 nF	-20/+80%	30V	Cer.
4C 6	47 nF	-20/+80%	12V	Cer.
4C 7	0.1 μF	-20/+80%	12V	Cer.
4C 8	2.2 nF	±1%	125V	Polyst.
4C 9	0.1 μF	-20/+80%	12V	Cer.
4C10	56 pF	±5%	400V	Cer.NP0
4C11	47 nF	-20/+80%	12V	Cer.
4C12	33 pF	±5%	400V	Cer.N150
4C13	51 pF	±5%	400V	Cer.N150
4C14	2.2 nF	±1%	125V	Polyst.
4C15	36 pF	±5%	400V	Cer.NP0
4C16	2.2 nF	±1%	125V	Polyst.
4C17	36 pF	±5%	400V	Cer.NP0
4C18	4.7 pF	±0.25pF	400V	Cer.N150
4C19	2.2 nF	±1%	125V	Polyst.
4C20	0.1 μF	-20/+80%	12V	Cer.
4C21	10 nF	-20/+80%	30V	Cer.
4C22	0.1 μF	-20/+80%	12V	Cer.
4C23	0.1 μF	10%	250V	Polyes.
4D 1	BZX79 C6V8	Zener		
4D 2	1S920			
4D 3	1S920			
4D 4	1S920			
4D 5	1S920			
4D 6	1S920			
4IC 1	SL641C			
4L 1	2.2 μH	RF CHOKE	±10%	
4L 2	COIL			SKANTI CODE: R-0312
4L 3	COIL			SKANTI CODE: R-0210
4L 4	100 μH	RF CHOKE	±10%	
4L 5	1 mH	RF CHOKE	±10%	
4L 6	FILTER COIL			SKANTI CODE: R-0218
4L 7	10 μH	RF CHOKE	±10%	
4L 8	FILTER COIL			SKANTI CODE: R-0218
4L 9	FILTER COIL			SKANTI CODE: R-0218
4L10	FILTER COIL			SKANTI CODE: R-0313
4L11	1 mH	RF CHOKE	±10%	



4R 1	1 kohm	5%	1/8W	Car.
4R 2	56 ohms	5%	1/8W	Car.
4R 3	47 ohms	5%	1/8W	Car.
4R 4	3.9 kohms	5%	1/8W	Car.
4R 5	1.8 kohms	5%	1/8W	Car.
4R 6	470 ohms	5%	1/8W	Car.
4R 7	2.2 kohms	5%	1/8W	Car.
4R 8	470 ohms	5%	1/8W	Car.
4R 9	1.2 kohms	5%	1/8W	Car.
4R10	1 kohm	5%	1/8W	Car.
4X 1	FILTER	445LQU914EM	10.7MHz	

PARTS LIST
FOR
IF AMPLIFIERS



5C 1	47 nF	-20/+80%	12V	Cer.
5C 2	10 nF	-20/+80%	30V	Cer.
5C 3	47 nF	-20/+80%	12V	Cer.
5C 4- 6	0.1 μ F	-20/+80%	12V	Cer.
5C 7	100 pF	\pm 5%	400V	Cer.N150
5C 8	22 pF	\pm 5%	400V	Cer.N150
5C 9-11	0.1 μ F	-20/+80%	12V	Cer.
5C12	360 pF	1%	125V	Polyst.
5C13	1 nF	1%	125V	Polyst.
5C14-18	0.1 μ F	-20/+80%	12V	Cer.
5C19	10 nF	-20/+80%	30V	Cer.
5C20	0.22 μ F	-20/+80%	12V	Cer.
5C21	0.1 μ F	-20/+80%	12V	Cer.
5C22	0.22 μ F	-20/+80%	12V	Cer.
5D 1	BZY88 C6V8	Zener		
5D 2- 6	1S920			
5IC 1	SL612C			
5IC 2	TBA120			
5IC 3	CA3026			
5L 1	1 mH	RF CHOKE	\pm 10%	
5L 2	22 μ H	RF CHOKE	\pm 10%	
5L 3	47 μ H	RF CHOKE	\pm 10%	
5R 1- 2	100 ohms	5%	1/8W	Car.
5P 3	56 ohms	5%	1/8W	Car.
5R 4	47 ohms	5%	1/8W	Car.
5R 5	8.2 kohms	5%	1/8W	Car.
5R 6	1.8 kohms	5%	1/8W	Car.
5R 7- 8	680 ohms	5%	1/8W	Car.
5R 9	100 ohms	5%	1/8W	Car.
5R10	390 ohms	5%	1/8W	Car.
5R11	270 ohms	5%	1/8W	Car.
5R12	390 ohms	5%	1/8W	Car.
5R13	100 ohms	5%	1/8W	Car.
5R14-15	3.9 kohms	5%	1/8W	Car.
5R16-17	180 ohms	5%	1/8W	Car.
5R18	220 ohms	5%	1/8W	Car.
5R19-20	100 ohms	5%	1/8W	Car.
5R21	220 ohms	5%	1/8W	Car.
5R22	68 ohms	5%	1/8W	Car.
5R23	180 ohms	5%	1/8W	Car.
5R24	82 ohms	5%	1/8W	Car.
5R25-26	3.9 kohms	5%	1/8W	Car.



5R27	100 ohms	5%	1/8W	Car.
5R28	4.7 kohms	5%	1/8W	Car.
5R29	2.7 kohms	5%	1/8W	Car.
5R30	1 kohm	5%	1/8W	Car.
5R31	680 ohms	5%	1/8W	Car.
5R32	4.7 kohms	5%	1/8W	Car.
5R33	180 ohms	5%	1/8W	Car.
5R34	10 kohms	5%	1/8W	Car.
5R35	2.2 kohms	5%	1/8W	Car.
5R36	100 ohms	5%	1/8W	Car.
5R37	1 kohm	5%	1/8W	Car.

5TR 1- 2 BF185

5X 1	FILTER	939 BB	SSB
5X 2	FILTER	939 DB	AM

PARTS LIST
FOR
DETECTORS



6C 1	0.1 μ F	-20/+80%	12V	Cer.
6C 2	4.7 nF	-20/+80%	30V	Cer.
6C 3	0.1 μ F	-20/+80%	12V	Cer.
6C 4	22 nF	-20/+80%	30V	Cer.
6C 5	1.2 r	\pm 1%	125V	Polyst.
6C 6- 7	not used			
6C 8-12	0.1 μ F	-20/+80%	12V	Cer.
6C13	4.7 nF	-20/+80%	30V	Cer.
6C14-15	0.1 μ F	-20/+80%	12V	Cer.
6C16-17	4.7 nF	-20/+80%	30V	Cer.
6C18	0.1 μ F	-20/+80%	12V	Cer.
6C19	0.22 μ F	-20/+80%	12V	Cer.
6C20	2.2 μ F	\pm 10%	100V	Polyes.
6C21	4.7 nF	-20/+80%	30V	Cer.
6C22-24	100 μ F		16V	W.alum.
6C25	0.1 μ F	-20/+80%	12V	Cer.
6C26	6.8 μ F	\pm 10%	100V	Polyes.
6D 1- 2	1S920			
6D 3	1N4148			
6D 4	1S920			
6D 5	1N4148			
6D 6- 9	Not used			
6D10	BZX79 C6V8	Zener		
6IC 1	TBA120			
6IC 2	SL621C			
6L 1	10 μ H	RF CHOKE	\pm 10%	
6L 2	1 mH	RF CHOKE	\pm 10%	
6R 1	10 kohms	5%	1/8W	Car.
6R 2	1.0 kohm	5%	1/8W	Car.
6R 3	100 ohms	5%	1/8W	Car.
6R 4- 6	2.2 kohms	5%	1/8W	Car.
6R 7	100 ohms	5%	1/8W	Car.
6R 8	2.2 kohms	5%	1/8W	Car.
6R 9	3.3 kohms	5%	1/8W	Car.
6R10	470 ohms	5%	1/8W	Car.
6R11	100 ohms	5%	1/8W	Car.
6R12	10 kohms	5%	1/8W	Car.
6R13	8.2 kohms	5%	1/8W	Car.
6R14	5.6 kohms	5%	1/8W	Car.
6R15	22 ohms	5%	1/8W	Car.
6R16	68 ohms	5%	1/8W	Car.
6R17	560 ohms	5%	1/8W	Car.
6R18	4.7 kohms	5%	1/8W	Car.



6R19	1.0 kohm	5%	1/8W	Car.
6R20	180 ohms	5%	1/8W	Car.
6R21	Not used			
6R22	100 kohms	5%	1/8W	Car.
6R23	68 ohms	5%	1/8W	Car.
6R24	10 kohms	5%	1/8W	Car.
6R25	3.3 kohms	5%	1/8W	Car.

6TR 1	BC109C
6TR 2- 3	BF185
6TR 4- 5	BC109C

PARTS LIST
FOR
AF AMPLIFIER



7C 1- 2	0.1 μ F	10%	100V	Polyes.
7C 3	4.7 nF	-20/+80%	30V	Cer.
7C 4	100 μ F		16V	W.alum.
7C 5	22 μ F	20%	15V	Tan.
7C 6- 7	0.22 μ F	-20/+80%	12V	Cer.
7D 1	1S920			
7D 2- 3	BZX79 C6V8	Zener		
7D 4- 5	1S920			
7IC 1	TAA300			
7R 1	3.3 kohms	5%	1/8W	Car.
7R 2	10 ohms	5%	1/8W	Car.
7R 3	220 ohms	5%	1/8W	Car.
7R 4	22 ohms	5%	1/8W	Car.
7R 5	3.9 ohms	5%	3W	ww
7T 1	TRANSFORMER		SKANTI CODE: R-0377	

PARTS LIST
FOR
9V VOLTAGE REGULATOR



8C 1	1.0 μ F	10%	100V	Polyes.
8C 2	100 μ F		16V	W.alum.
8C 3	0.47 μ F	10%	100V	Polyes.
8C 4	0.1 μ F	10%	250V	Polyes.
8D 1- 7	1S920			
8D 8	BZX79 C6V8	Zener		
8D 9-10	1S920			
8R 1	1.0 kohm	5%	1/8W	Car.
8R 2	10 kohms	5%	1/8W	Car.
8R 3	680 ohms	5%	1/8W	Car.
8R 4	68 kohms	5%	1/8W	Car.
8R 5	680 ohms	5%	1/8W	Car.
8R 6	10 kohms	Var.		Car.
8R 7	5.6 kohms	5%	1/8W	Car.
8R 8	1.0 kohm	Var.		Car.
8TR 1	BC161/10			
8TR 2	2N1613			

PARTS LIST
FOR
CHANNEL OSCILLATOR



9C 1	47 nF	-20/+80%	12V	Cer.
9C 2	0.1 μ F	-20/+80%	12V	Cer.
9C 3	680 pF	1%	125V	Polyst.
9C 4-12	18 pF	5%	400V	Cer.NP0
9C13-14	47 nF	-20/+80%	12V	Cer.
9C15-23	20 pF	Var.		Cer.
9C24-32	18 pF	5%	400V	Cer.NP0
9C33-34	47 nF	-20/+80%	12V	Cer.
9C35-43	20 pF	Var.		Cer.
9C44-52	18 pF	5%	400V	Cer.NP0
9C53	47 nF	-20/+80%	12V	Cer.
9C54-62	20 pF	Var.		Cer.
9C63-64	47 nF	-20/+80%	12V	Cer.
9C65-73	18 pF	5%	400V	Cer.NP0
9C74	47 nF	-20/+80%	12V	Cer.
9C75-83	20 pF	Var.		Cer.
9C84-92	18 pF	5%	400V	Cer.NP0
9C93	47 nF	-20/+80%	12V	Cer.
9C94	82 pF	5%	400V	Cer.N150
9C95-103	20 pF	Var.		Cer.
9C104-112	18 pF	5%	400V	Cer.NP0
9C113	47 nF	-20/+80%	12V	Cer.
9C114	4.7 nF	-20/+80%	30V	Cer.
9C115-123	20 pF	Var.		Cer.
9C124-132	18 pF	5%	400V	Cer.NP0
9C133-134	47 nF	-20/+80%	12V	Cer.
9C135-143	20 pF	Var.		Cer.
9C144	47 nF	-20/+80%	12V	Cer.
9C145-153	18 pF	5%	400V	Cer.NP0
9C154	47 nF	-20/+80%	12V	Cer.
9C155-163	20 pF	Var.		Cer.
9C164	22 μ F	20%	15V	neto
9C165	220 pF	1%	125V	Polyst.
9C166-168	18 pF	5%	400V	Cer.NP0
9C169-177	47 nF	-20/+80%	12V	Cer.
9C178-180	20 pF	Var.		Cer.
9C181	0.1 μ F	-20/+80%	12V	Cer.
9C182-184	18 pF	5%	400V	Cer.NP0
9C185	47 nF	-20/+80%	12V	Cer.
9C186-188	20 pF	Var.		Cer.
9C189-191	47 nF	-20/+80%	12V	Cer.
9C192	0.1 μ F	-20/+80%	12V	Cer.
9D 1-88	1S920			
9L 1- 8	1 mH	RF CHOKE	10%	
9L 9-10	100 μ H	RF CHOKE	10%	
9L11-13	1 mH	RF CHOKE	10%	

9R 1	10 kohms	5%	1/8W	Car.
9R 2	15 ohms	5%	1/8W	Car.
9R 3-11	10 kohms	5%	1/8W	Car.
9R12	12 kohms	5%	1/8W	Car.
9R13	82 ohms	5%	1/8W	Car.
9R14	1.0 kohm	5%	1/8W	Car.
9R15-23	10 kohms	5%	1/8W	Car.
9R24	12 kohms	5%	1/8W	Car.
9R25	82 ohms	5%	1/8W	Car.
9R26	1.0 kohm	5%	1/8W	Car.
9R27	2.2 kohms	5%	1/8W	Car.
9R28-36	10 kohms	5%	1/8W	Car.
9R37	12 kohms	5%	1/8W	Car.
9R38	82 ohms	5%	1/8W	Car.
9R39	4.7 kohms	5%	1/8W	Car.
9R40	10 kohms	5%	1/8W	Car.
9R41	2.2 kohms	5%	1/8W	Car.
9R42-50	10 kohms	5%	1/8W	Car.
9R51	12 kohms	5%	1/8W	Car.
9R52	82 ohms	5%	1/8W	Car.
9R53	2.2 kohms	5%	1/8W	Car.
9R54	120 ohms	5%	1/8W	Car.
9R55	470 ohms	5%	1/8W	Car.
9R56-64	10 kohms	5%	1/8W	Car.
9R65	12 kohms	5%	1/8W	Car.
9R66	82 ohms	5%	1/8W	Car.
9R67	150 ohms	5%	1/8W	Car.
9R68	180 ohms	5%	1/8W	Car.
9R69-78	10 kohms	5%	1/8W	Car.
9R79	12 kohms	5%	1/8W	Car.
9R80	82 ohms	5%	1/8W	Car.
9R81-90	10 kohms	5%	1/8W	Car.
9R91	12 kohms	5%	1/8W	Car.
9R92	82 ohms	5%	1/8W	Car.
9R93	330 ohms	5%	1/8W	Car.
9R94	2.2 kohms	5%	1/8W	Car.
9R95-103	10 kohms	5%	1/8W	Car.
9R104	12 kohms	5%	1/8W	Car.
9R105	82 ohms	5%	1/8W	Car.
9R106-112	270 ohms	5%	1/8W	Car.
9R113-118	12 kohms	5%	1/8W	Car.
9R119-121	10 kohms	5%	1/8W	Car.
9R122	12 kohms	5%	1/8W	Car.
9R123	82 ohms	5%	1/8W	Car.
9R124	12 kohms	5%	1/8W	Car.
9R125-127	10 kohms	5%	1/8W	Car.
9R128	12 kohms	5%	1/8W	Car.
9R129	82 ohms	5%	1/8W	Car.
9R130-132	270 ohms	5%	1/8W	Car.
9R133-135	12 kohms	5%	1/8W	Car.
9TR 1- 2	BF185			
9TR 3	BSX19			
9TR 4	BF185			
9TR 5	BC109C			

PARTS LIST
FOR
CLARIFIER OSCILLATOR



10C 1	not used			
10C 2	100 pF	5%	400V	Cer.N750
10C 3	0.1 μ F	-20/+80%	12V	Cer.
10C 4	150 pF	5%	400V	Cer.N150
10C 5	0.1 μ F	10%	250V	Polyes.
10IC 1	SN7400N			
10IC 2	SN7473N			
10L 1	COIL			SKANTI CODE: R-0307
10L 2	100 μ H	RF CHOKE	10%	
10L 3	220 μ H	RF CHOKE	10%	
10L 4	22 μ H	RF CHOKE	10%	
10R 1	470 ohms	5%	1/8W	Car.
10R 2- 3	1 kohm	5%	1/8W	Car.
10R 4	470 ohms	5%	1/8W	Car.
10R 5	56 ohms	5%	1/8W	Car.
10R 6	120 ohms	5%	1/8W	Car.
10X 1	CRYSTAL			SKANTI CODE: R-0310

PARTS LIST
FOR
MASTER OSCILLATOR



11C 1	47 pF	5%	400V	Cer.N150
11C 2	0.1 μF	10%	250V	Polyes.
11C 3	0.1 μF	-20/+80%	12V	Cer.
11C 4	100 pF	5%	400V	Cer.N150
11C 5	1 nF	1%	125V	Polyst.
11C 6- 8	0.1 μF	-20/+80%	12V	Cer.
11D 1	BZX79 C9V1	Zener		
11D 2- 5	1S920			
11D 6- 7	AAZ 17			
11IC 1	SN7473N			
11L 1	2.2 μH	RF CHOKE	10%	
11L 2	100 μH	RF CHOKE	10%	
11R 1	56 ohms	5%	1/8W	Car.
11R 2	10 kohms	5%	1/8W	Car.
11R 3	68 kohms	5%	1/8W	Car.
11R 4	2.2 kohms	5%	1/8W	Car.
11R 5	100 ohms	5%	1/8W	Car.
11R 6	18 kohms	5%	1/8W	Car.
11R 7- 8	2.7 kohms	5%	1/8W	Car.
11R 9	10 kohms	5%	1/8W	Car.
11R10	100 ohms	5%	1/8W	Car.
11R11	470 ohms	5%	1/8W	Car.
11R12	15 kohms	5%	1/8W	Car.
11R13	1 kohm	5%	1/8W	Car.
11R14	2.2 kohms	5%	1/8W	Car.
11R15	1 kohm	5%	1/8W	Car.
11R16-17	2.2 kohms	5%	1/8W	Car.
11R18	100 ohms	5%	1/8W	Car.
11T 1	TRANSFORMER		SKANTI CODE: R-0222	
11TR 1- 2	BF185			
11X 1	OSCILLATOR TCXO		5.6 MHz	

PARTS LIST
FOR
12.1MHz MIXER



12C 1	0.1 μ F	10%	250V	Polyes.
12C 2	22 nF	-20/+80%	30V	Cer.
12C 3	22 nF	-20/+80%	30V	Cer.
12C 4	0.1 μ F	-20/+80%	12V	Cer.
12C 5	22 nF	-20/+80%	30V	Cer.
12C 6	22 nF	-20/+80%	30V	Cer.
12C 7	22 nF	-20/+80%	30V	Cer.
12C 8	475 pF	1%	125V	Polyst.
12C 9	1.2 nF	1%	125V	Polyst.
12C10	6.8 nF	1%	63V	Polyst.
12IC 1	TBA120			
12L 1	COIL		SKANTI CODE: R-0213	
12L 2	4.7 μ H	RF CHOKE	10%	
12R 1	3.9 kohms	5%	1/8W	Car.
12R 2	56 ohms	5%	1/8W	Car.
12R 3	470 ohms	5%	1/8W	Car.
12R 4	56 ohms	5%	1/8W	Car.
12R 5	47 ohms	5%	1/8W	Car.
12R 6	220 ohms	5%	1/8W	Car.
12TR 1	BC109C			

PARTS LIST
FOR
VOLTAGE CONTROLLED OSCILLATOR



13C 1	2.2 μ F	10%	100V	Polyes.
13C 2	0.1 μ F	-20/+80%	12V	Cer.
13C 3	4.7 nF	-20/+80%	30V	Cer.
13C 4	3.3 nF	1%	63V	Polyst.
13C 5	0.1 μ F	-20/+80%	12V	Cer.
13C 6	22 pF	5%	400V	Cer.N150
13C 7	470 pF	1%	125V	Polyst.
13C 8- 9	4.7 nF	-20/+80%	30V	Cer.
13C10	0.1 μ F	-20/+80%	12V	Cer.
13C11-12	8.2 pF	\pm 0.25pF	400V	Cer.N150
13C13-14	15 pF	5%	400V	Cer.N150
13C15	0.1 μ F	-20/+80%	12V	Cer.
13C16	12 pF	5%	400V	Cer.N150
13C17	0.1 μ F	-20/+80%	12V	Cer.
13C18	22 pF	5%	400V	Cer.N150
13C19	0.1 μ F	-20/+80%	12V	Cer.
13C20	4.7 nF	-20/+80%	30V	Cer.
13C21	0.22 μ F	-20/+80%	12V	Cer.
13C22	0.1 μ F	-20/+80%	12V	Cer.
13C23	470 μ F		16V	W.alum.

13D 1- 5	1S920			
13D 6- 7	BB103 green Varicap			
13D 8	AAZ17			
13D 9-11	1S920			

13IC 1	SN7403N			
13IC 2	SN7493N			

13L 1- 3	100 μ H	RF CHOKE	10%	
13L 4	COIL		SKANTI CODE: R-0212	
13L 5- 6	100 μ H	RF CHOKE	10%	
13L 7	COIL		SKANTI CODE: R-0214	
13L 8	COIL		SKANTI CODE: R-0211	

13R 1	47 kohms	5%	1/8W	Car.
13R 2	100 kohms	5%	1/8W	Car.
13R 3	1 Mohm	5%	1/8W	Car.
13R 4	220 ohms	5%	1/8W	Car.
13R 5	4.7 kohms	5%	1/8W	Car.
13R 6	22 kohms	5%	1/8W	Car.
13R 7	2.7 kohms	5%	1/8W	Car.
13R 8	180 ohms	5%	1/8W	Car.
13R 9	2.2 kohms	5%	1/8W	Car.
13R10	10 kohms	5%	1/8W	Car.

13R11	5.6 kohms	5%	1/8W	Car.
13R12	100 ohms	5%	1/8W	Car.
13R13	3.3 kohms	5%	1/8W	Car.
13R14-17	330 kohms	5%	1/8W	Car.
13R18	47 ohms	5%	1/8W	Car.
13R19-20	2.2 kohms	5%	1/8W	Car.
13R21	180 ohms	5%	1/8W	Car.
13R22	680 ohms	5%	1/8W	Car.
13R23	10 kohms	5%	1/8W	Car.
13R24	22 kohms	5%	1/8W	Car.
13R25	82 ohms	5%	1/8W	Car.
13R26	4.7 kohms	5%	1/8W	Car.

13TR 1	BC177B
13TR 2	BSX19
13TR 3- 6	BF185

PARTS LIST
FOR
LOOP MIXER AND PHASE DETECTOR



14C 1	0.1 μ F	-20/+80%	12V	Cer.
14C 2	10 nF	-20/+80%	30V	Cer.
14C 3	10 nF	-20/+80%	30V	Cer.
14C 4	0.1 μ F	10%	250V	Polyes.
14C 5	0.1 μ F	-20/+80%	12V	Cer.
14C 6	39 pF	5%	400V	Cer.N150
14C 7	33 pF	5%	400V	Cer.N150
14C 8	10 nF	-20/+80%	30V	Cer.
14C 9	10 nF	-20/+80%	30V	Cer.
14C10	4.7 nF	-20/+80%	30V	Cer.
14C11	22 nF	-20/+80%	30V	Cer.
14C12	18 pF	5%	400V	Cer.N150
14C13	0.1 μ F	-20/+80%	12V	Cer.
14C14	10 nF	-20/+80%	30V	Cer.
14C15	0.1 μ F	-20/+80%	12V	Cer.
14C16	10 nF	-20/+80%	30V	Cer.
14C17	0.1 μ F	-20/+80%	12V	Cer.
14C18	0.1 μ F	-20/+80%	12V	Cer.
14C19	0.1 μ F	-20/+80%	12V	Cer.
14C20	0.1 μ F	-20/+80%	12V	Cer.
14C21	47 pF	5%	400V	Cer.N150
14C22	47 pF	5%	400V	Cer.N150
14C23	100 pF	5%	400V	Cer.N150
14C24	22 μ F	20%	15V	Tan.
14C25	0.1 μ F	-20/+80%	12V	Cer.
14C26	100 pF	5%	400V	Cer.N150
14D 1	1S920			
14D 2	1S920			
14D 3	1S920			
14D 4	1S920			
14D 5	1S920			
14D 6	1S920			
14D 7	AAZ 17			
14D 8	AAZ 17			
14IC 1	SL641C			
14L 1	100 μ H	RF CHOKE	10%	
14L 2	100 μ H	RF CHOKE	10%	
14L 3	COIL		SKANTI CODE: R-0241	
14L 4	100 μ H	RF CHOKE	10%	
14L 5	1 mH	RF CHOKE	10%	

PARTS LIST
FOR
FILTERS FOR 4.2-9.8 AND 12.6 MHz



15C 1- 2	22 nF	-20/+80%	30V	Cer.
15C 3- 5	47 nF	-20/+80%	12V	Cer.
15C 6	0.1 μF	-20/+80%	12V	Cer.
15C 7	330 pF	1%	125V	Polyst.
15C 8	1 nF	1%	125V	Polyst.
15C 9	330 pF	1%	125V	Polyst.
15C10	910 pF	1%	125V	Polyst.
15C11	1.8 pF	±0.25pF	400V	Cer.NP0
15C12	5.6 pF	±0.25pF	400V	Cer.N150
15C13	270 pF	1%	125V	Polyst.
15C14	0.1 μF	-20/+80%	12V	Cer.
15C15	330 pF	1%	125V	Polyst.
15C16	1 nF	1%	125V	Polyst.
15C17	330 pF	1%	125V	Polyst.
15C18	910 pF	1%	125V	Polyst.
15C19	2.7 pF	±0.25pF	400V	Cer.NP0
15C20-21	47 nF	-20/+80%	12V	Cer.
15C22	330 pF	1%	125V	Polyst.
15C23	1.2 nF	1%	125V	Polyst.
15C24-25	47 nF	-20/+80%	12V	Cer.

15D 1-10 1S920

15L 1	COIL	SKANTI CODE: R-0215
15L 2	COIL	SKANTI CODE: R-0216
15L 3	COIL	SKANTI CODE: R-0215
15L 4	COIL	SKANTI CODE: R-0216
15L 5	COIL	SKANTI CODE: R-0235
15L 6	COIL	SKANTI CODE: R-0217

15R 1	18 kohms	5%	1/8W	Car.
15R 2	6.8 kohms	5%	1/8W	Car.
15R 3	3.3 kohms	5%	1/8W	Car.
15R 4	100 ohms	5%	1/8W	Car.
15R 5	1.2 kohms	5%	1/8W	Car.
15R 6- 7	1.5 kohms	5%	1/8W	Car.
15R 8	10 kohms	5%	1/8W	Car.
15R 9	1.5 kohms	5%	1/8W	Car.
15R10	10 kohms	5%	1/8W	Car.
15R11	2.2 kohms	5%	1/8W	Car.
15R12-13	82 ohms	5%	1/8W	Car.
15R14	1.0 kohm	5%	1/8W	Car.
15R15	10 kohms	5%	1/8W	Car.
15R16	82 ohms	5%	1/8W	Car.
15R17-18	2.2 kohms	5%	1/8W	Car.



15R19	1.0 kohms	5%	1/8W	Car.
15R20	470 ohms	5%	1/8W	Car.
15R21	1.0 kohm	5%	1/8W	Car.
15R22	10 kohms	5%	1/8W	Car.
15R23	100 ohms	5%	1/8W	Car.
15R24	4.7 kohms	5%	1/8W	Car.
15R25	100 ohms	5%	1/8W	Car.

15TR 1- 2 BF185

PARTS LIST
 FOR
 RFI FILTERS



16C 1- 2	47 nF		1000V	MP
16C 3- 6	0.1 μ F	$\pm 10\%$	250V	Polyes.
16D 1	BZX79 C6V8	Zener		
16L 1- 2	25 μ H	RF CHOKE	3A	
16L 3- 5	47 μ H	RF CHOKE	10%	
16L 6- 7	25 μ H	RF CHOKE	3A	
16L 8-12	47 μ H	RF CHOKE	10%	
16R 1- 2	330 ohms	5%	1/8W	Car.

PARTS LIST
FOR
CHASSIS (electrical parts)



17C 1	15 nF	-20/+80%	400V	Cer.
17C 2	0.1 μ F	10%	250V	Polyes.
17C 3	15 nF	-20/+80%	400V	Cer.
17C 4	47 nF	10%	250V	Polyes.
17C 5	0.1 μ F	10%	250V	Polyes.
17C 6	4.7 nF	\pm 20%	5kV	Cer.
17C 7	47 nF	10%	250V	Polyes.
17C 8	22 nF	-20/+80%	30V	Cer.
17C 9	22 nF	-20/+80%	30V	Cer.
17D 1	388A			
17D 2	388A			
17D 3	1S920			
17D 4	BZX79 C6V8	Zener		
17L 1	1 mH	RF CHOKE	\pm 10%	
17L 2	100 μ H	RF CHOKE	\pm 10%	
17LS 1	8 ohms	0.5W		LOUDSPEAKER
17PL 1	1 pole connector (plug)			SKANTI CODE: R-0233
17PL 2	12 pole connector (plug)		XP12	McMurdo
17R 1	10 kohms	5%	1 W	Car.
17R 2	10 kohms	5%	1/8 W	Car.
17R 3	100 ohms	5%	1/8 W	Car.
17R 4	10 kohms	5%	1/8 W	Car.
17R 5	10 kohms	log.	1/3 W	Var.Car.
17R 6	2.2 kohms	5%	1/8 W	Car.
17R 7	10 kohms	lin.	1/3 W	Var.Car.
17R 8	330 ohms	5%	1/8 W	Car.
17R 9	8.2 ohms	5%	1 W	ww
17S 1a,b,c,d	service	ROTARY SWITCH		SKANTI CODE: R-0224
17S 2a,b,c	band	ROTARY SWITCH		SKANTI CODE: R-0225
17S 3	mode	ROTARY SWITCH		SKANTI CODE: R-0223
17S 4	speaker	ROTARY SWITCH		SKANTI CODE: R-0223
17S 5a,b	channel	ROTARY SWITCH		SKANTI CODE: R-0226
17SK 1	connector (socket)		BNC UG657/U	
17SK 2	connector (socket)		BNC UG657/U	isol.
17SK 3	4 pole connector (socket)		XS4	McMurdo
17SL 1	LAMP	12V	913 0012	Schurter
17TR 1	2N3055			
17TR 2	2N3055			

PARTS LIST
FOR
DC POWER PACK



18C 1	680 μ F	-10/+50%	63V	W.alum.
18D 1	BZY93 C39	Zener		
18FS 1	1.6A	FAST	6.3 ϕ x 32mm	
18FS 2	1.6A	FAST	6.3 ϕ x 32mm	
18R 1	2.7 kohms	\pm 5%	1/2W	Car.

PARTS LIST
 FOR
 AC POWER PACK



19C 1	3300 μ F		16V	W.alum.
19D 1	1N5401			
19D 2	1N5401			
19D 3	1N5401			
19D 4	1N5401			
19FS 1	110V	315mA	SLOW	6.3 ϕ x 32mm
	220V	160mA	SLOW	6.3 ϕ x 32mm
	380/440V	80mA	SLOW	6.3 ϕ x 32mm
19FS 2	1.6A		FAST	6.3 ϕ x 32mm
19R 1	560 ohms	5%	1/2W	Car.
19T 1	TRANSFORMER			SKANTI CODE: R-0309

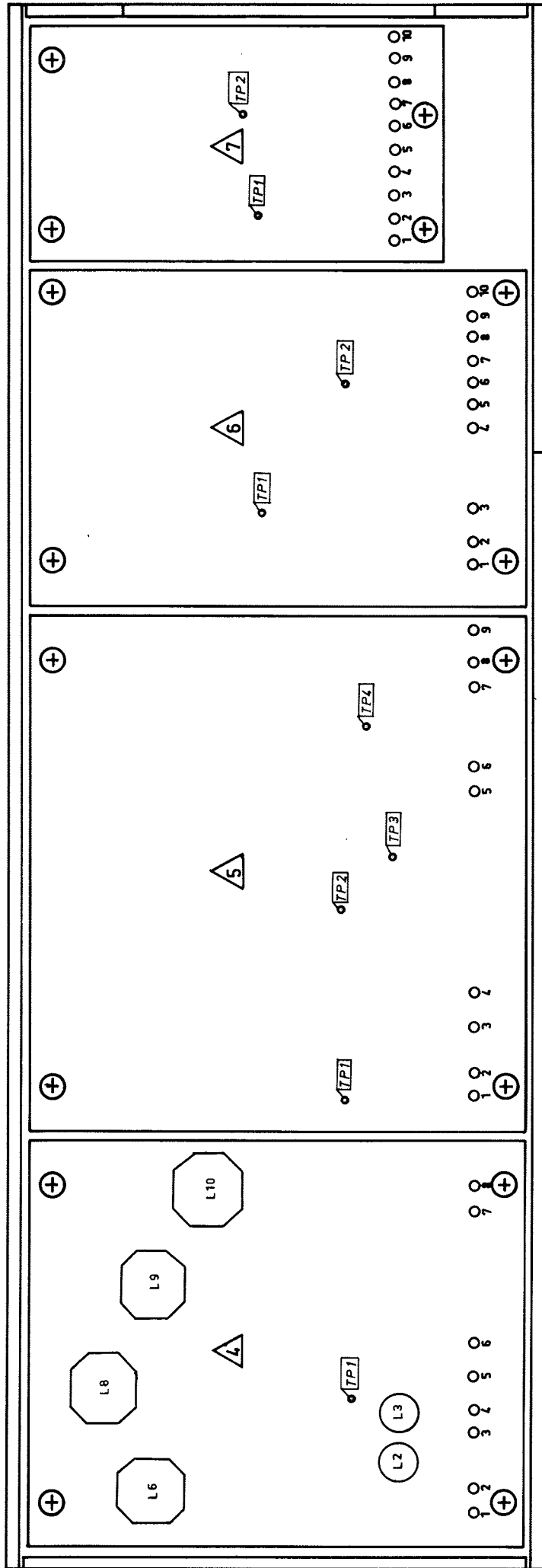

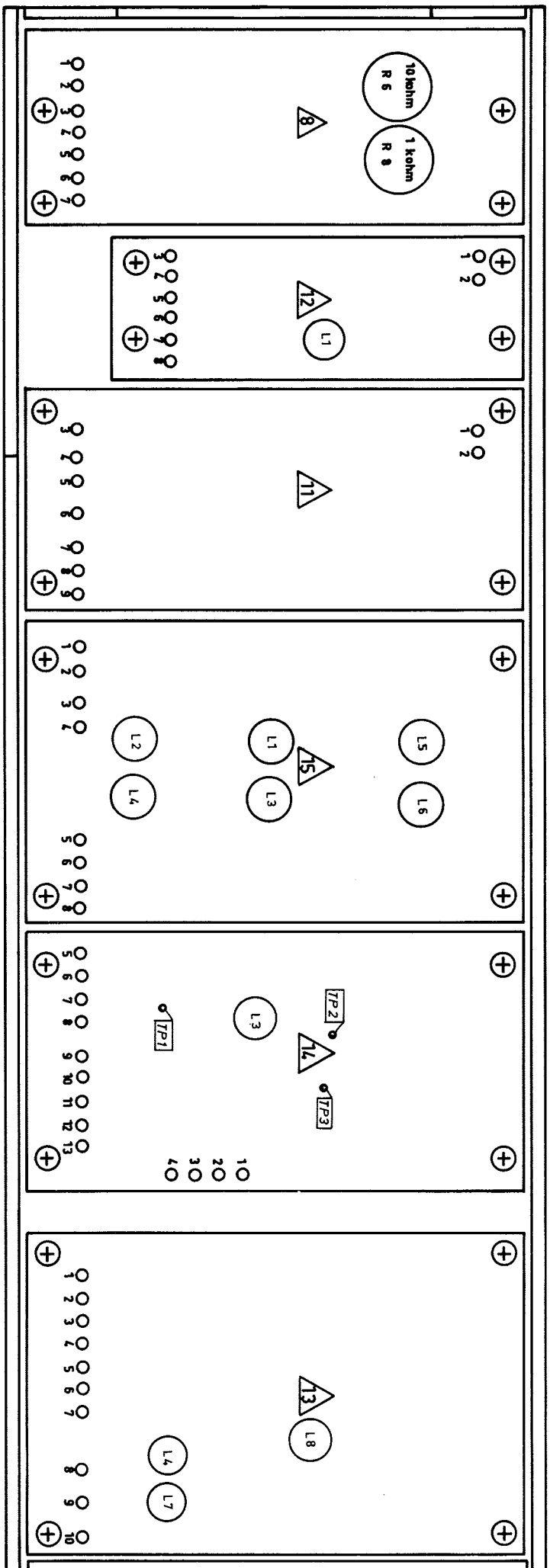

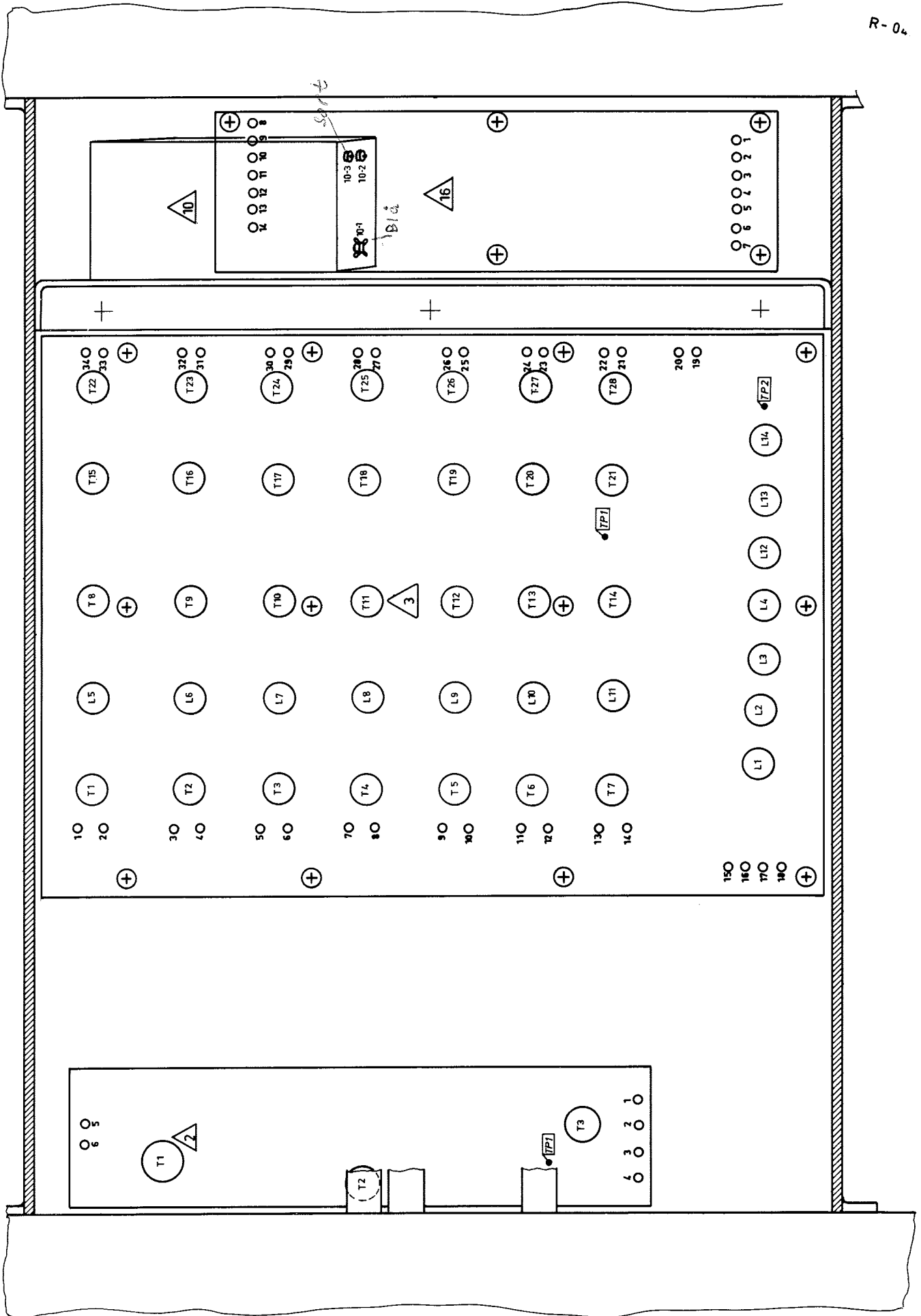

R-0402 - 1 CIRCUIT BOARD LOCATION PLAN BOTTOM COMPARTMENT

R-0403 - 1 CIRCUIT BOARD LOCATION PLAN TOP COMPARTMENT

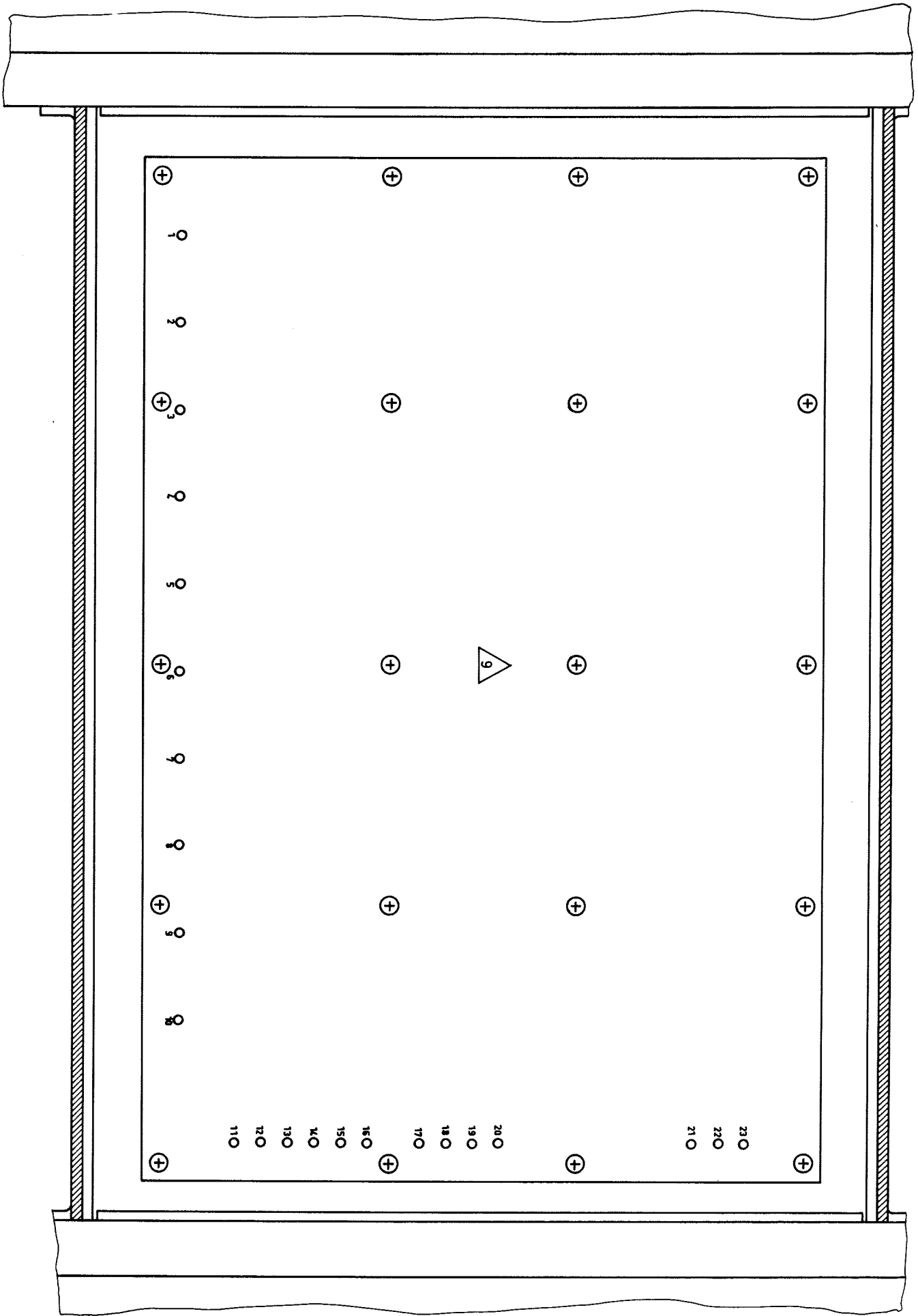

R-0311 - 1 CIRCUIT DIAGRAM OF TBA 120

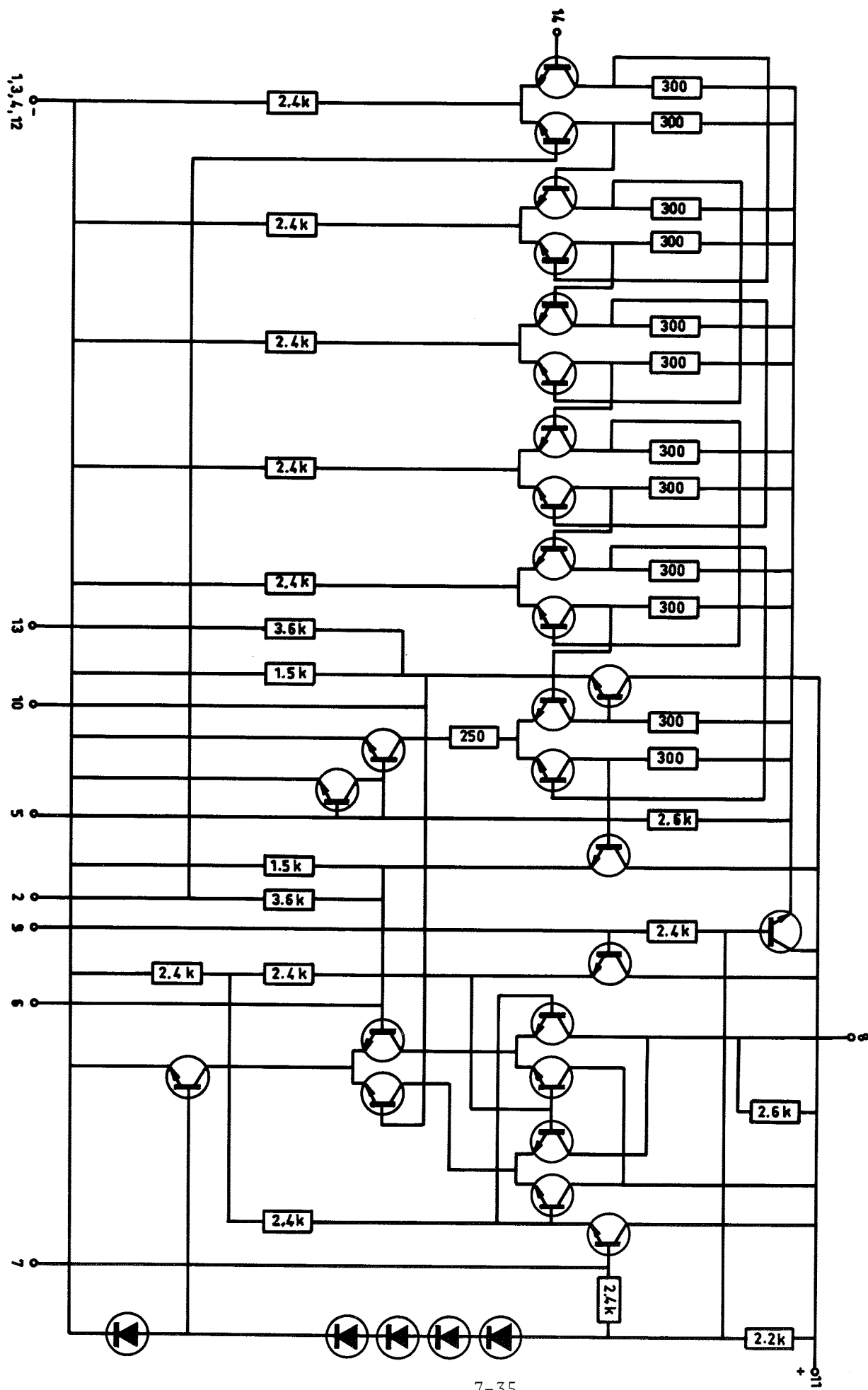

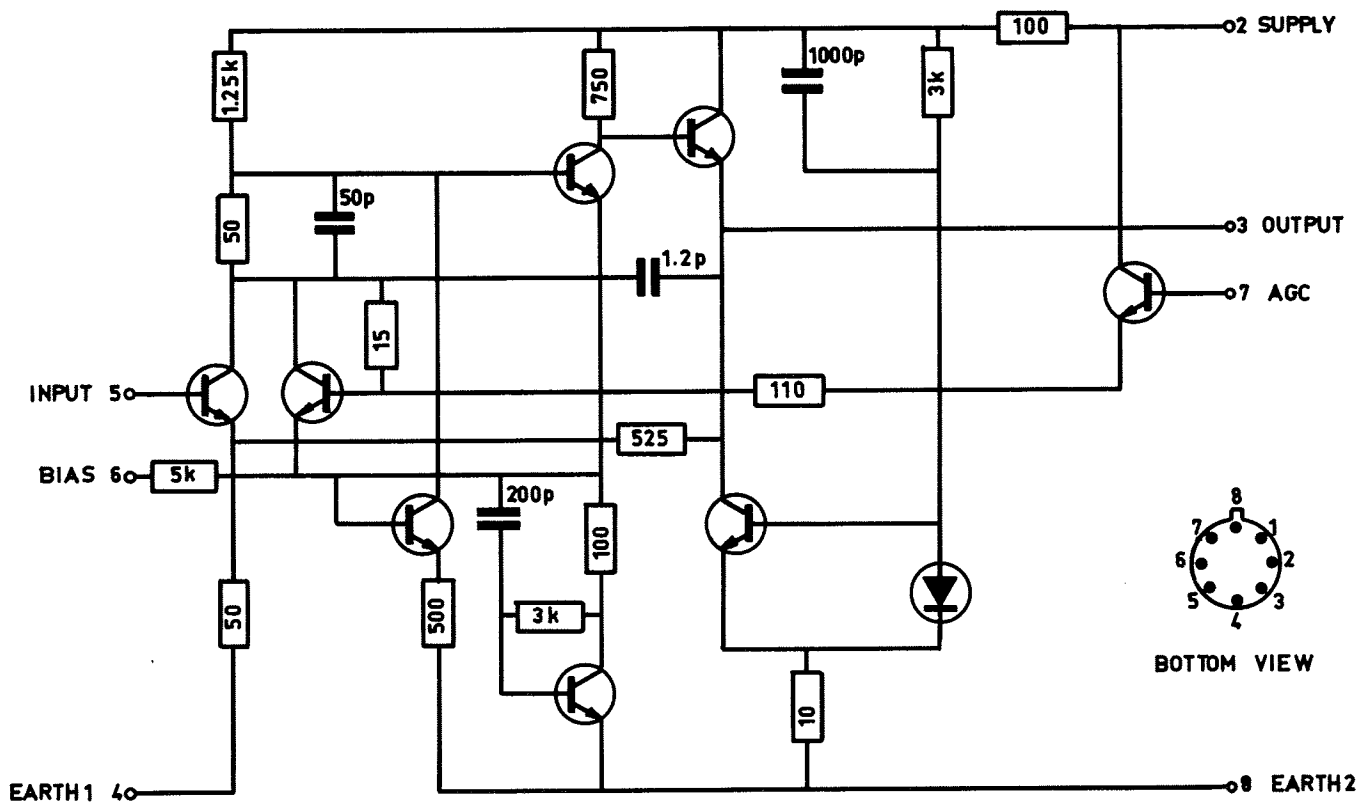

R-0321-1 CIRCUIT DIAGRAM OF SL610C

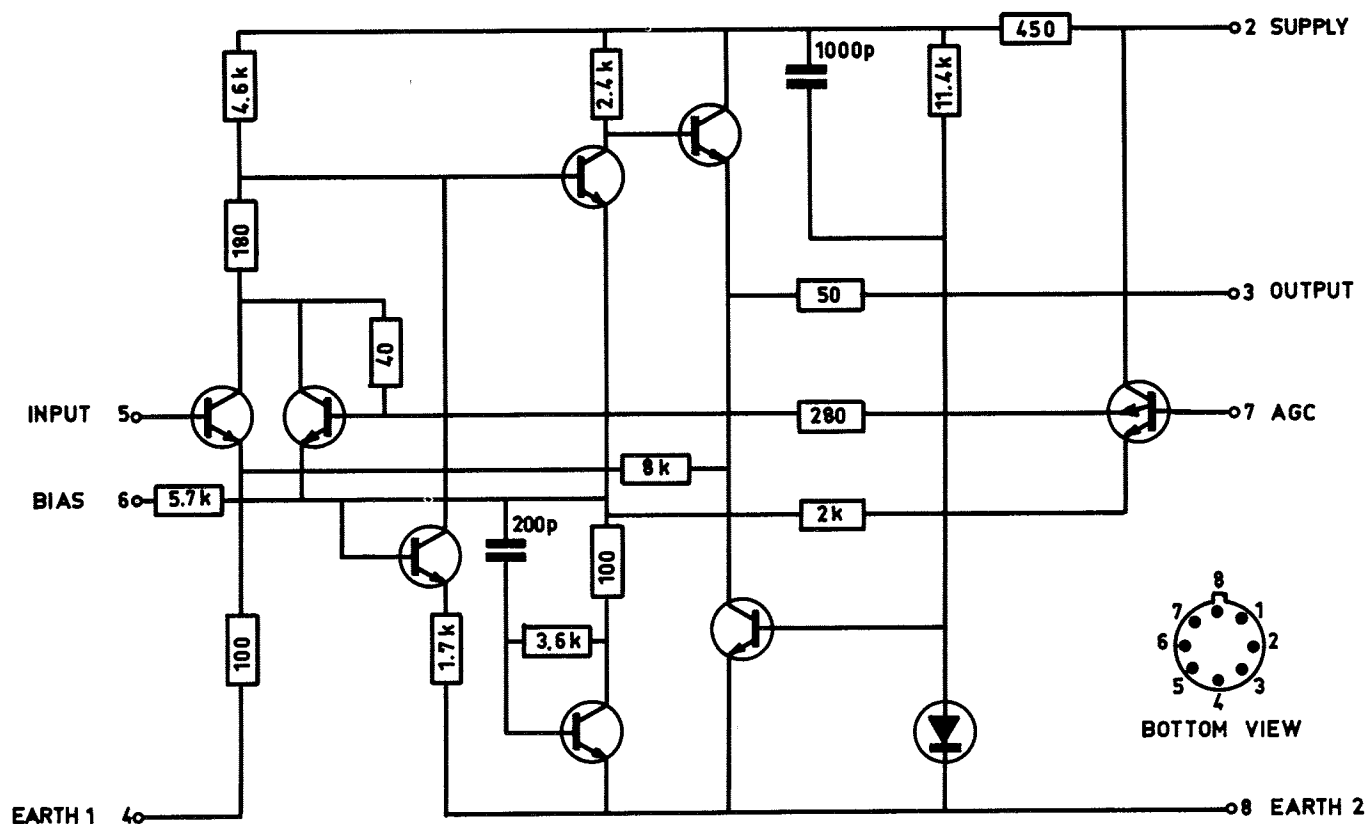

R-0322-1 CIRCUIT DIAGRAM OF SL612C

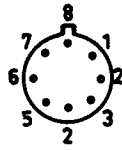

BOTTOM VIEW

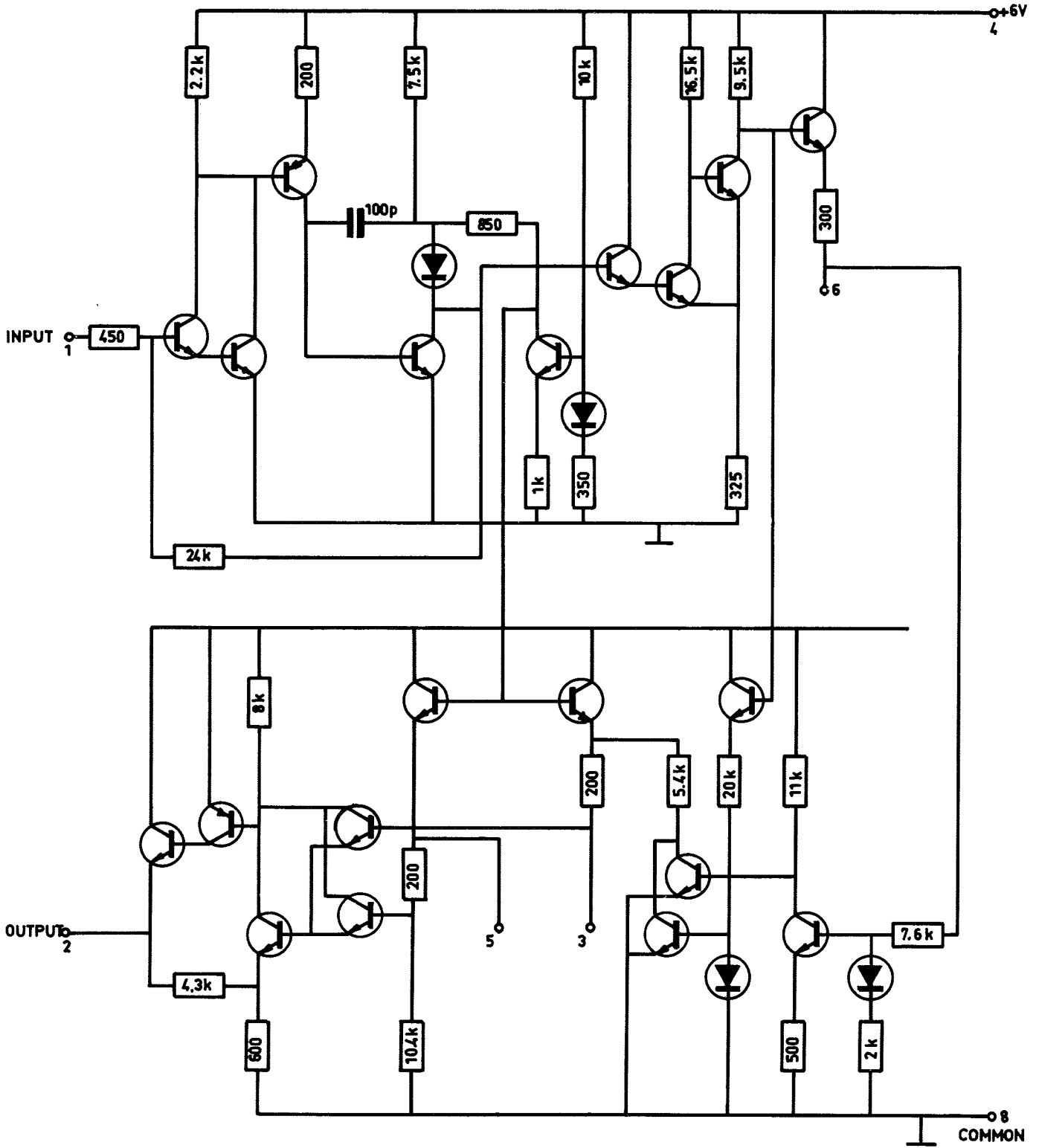

R-0324-1 CIRCUIT DIAGRAM OF SL641C

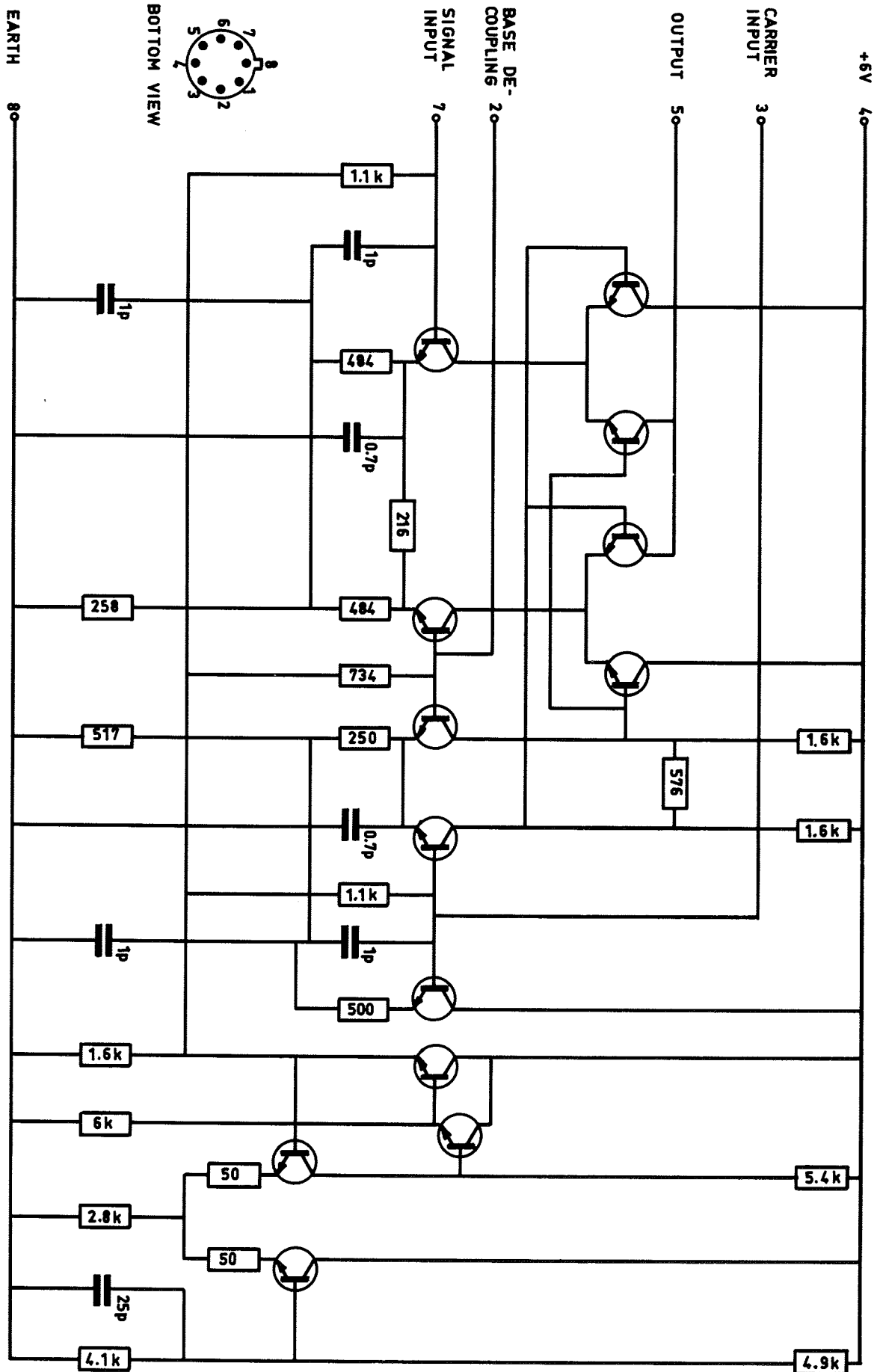

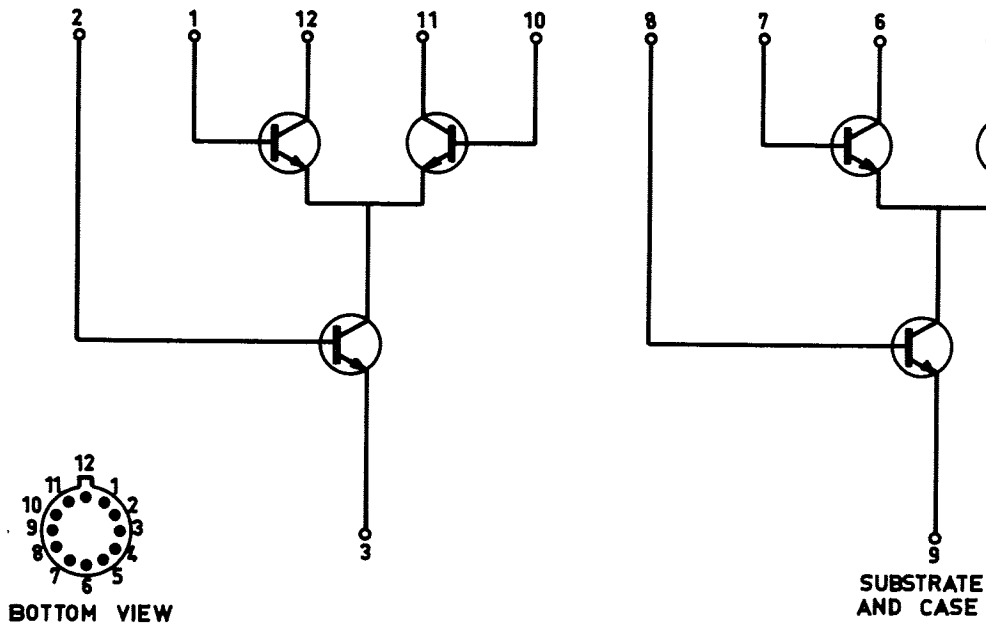

R-0325 - 1 CIRCUIT DIAGRAM OF CA3026

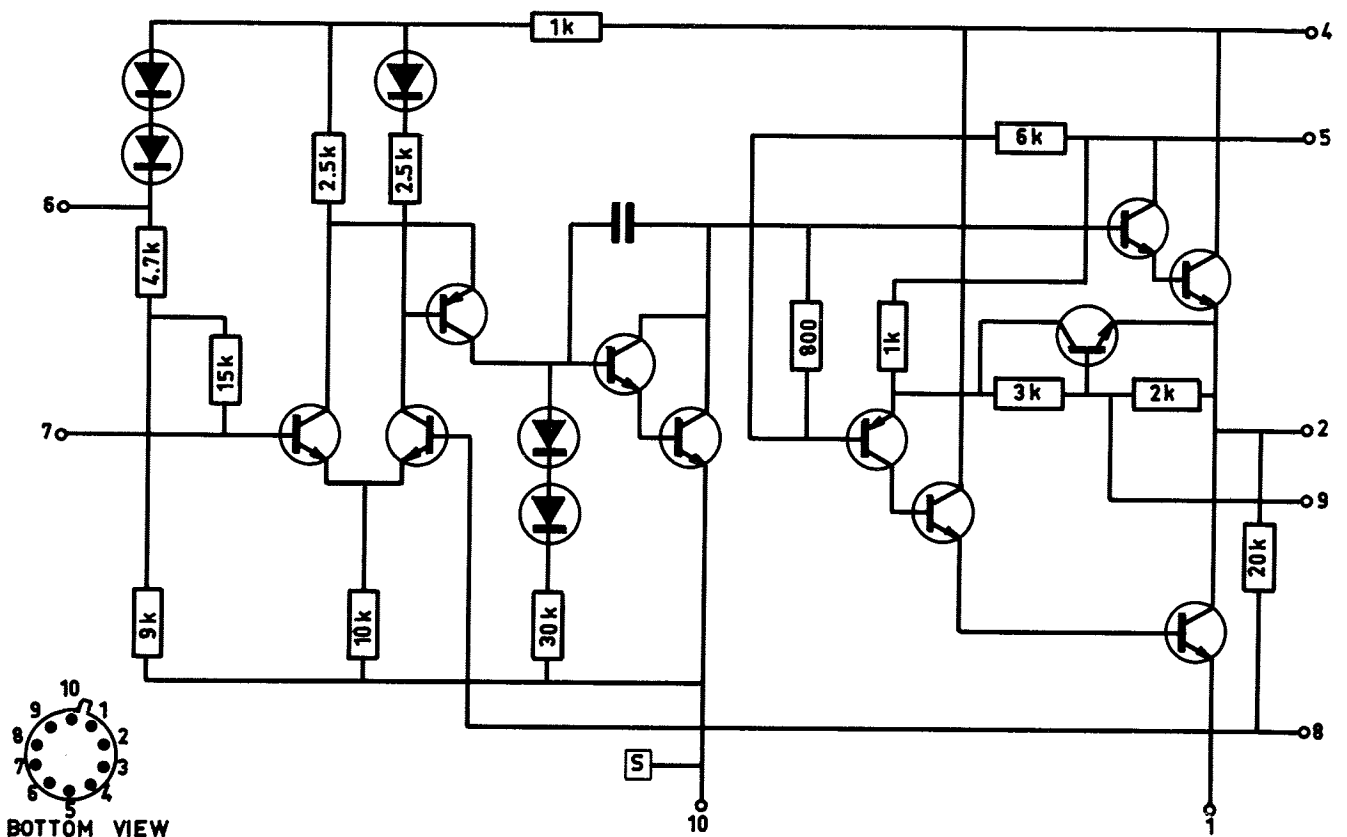

R-0326 - 1 CIRCUIT DIAGRAM OF TAA 300

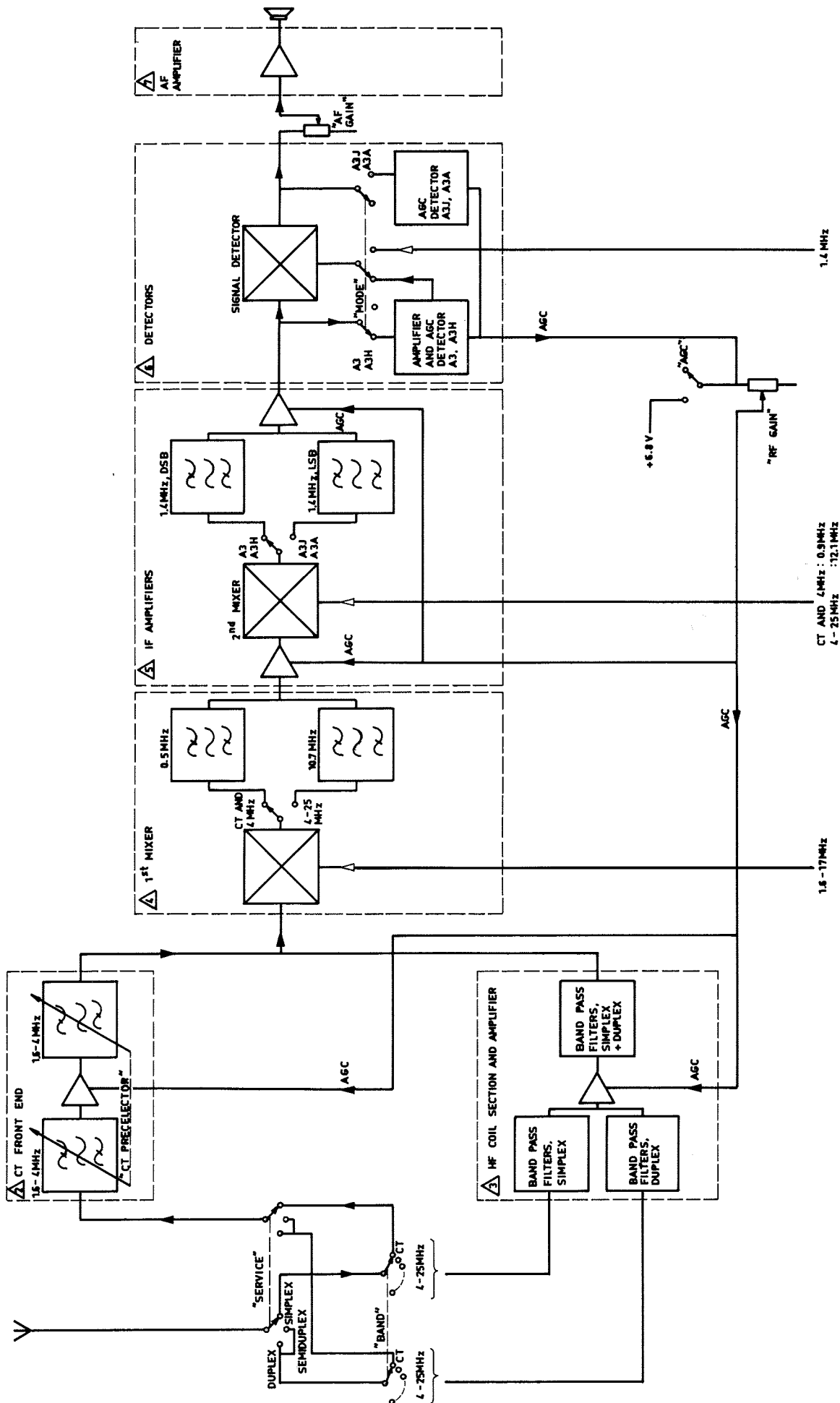

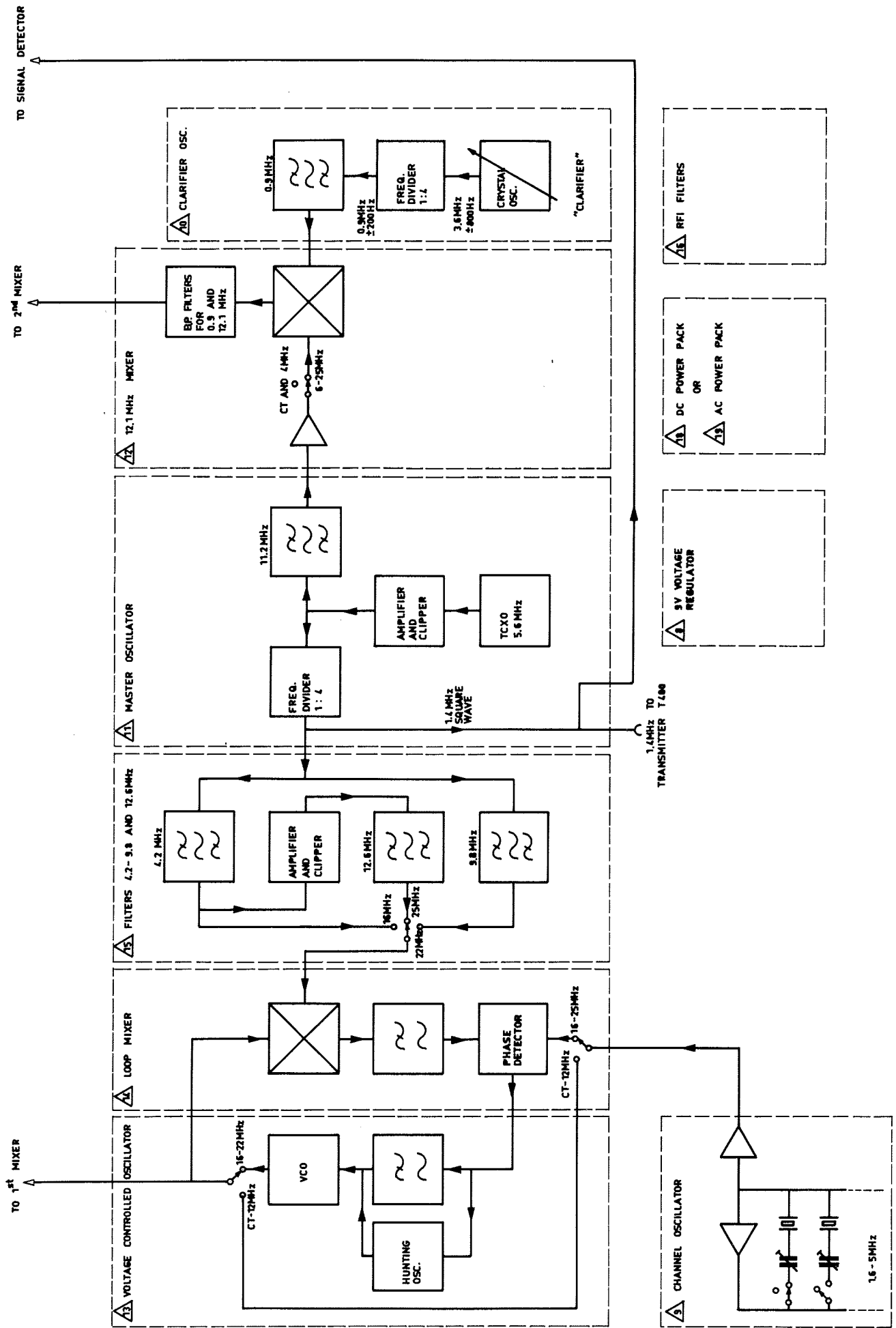

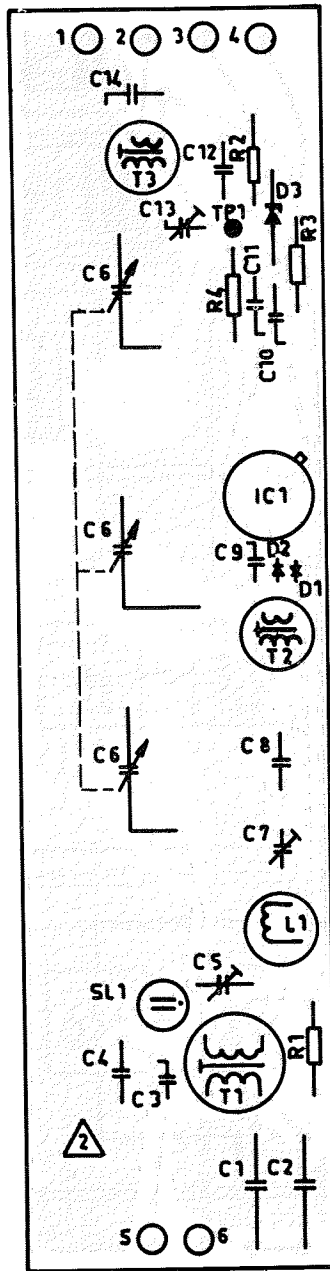

PRINTED CIRCUIT BOARD VIEWED FROM COMPONENT SIDE

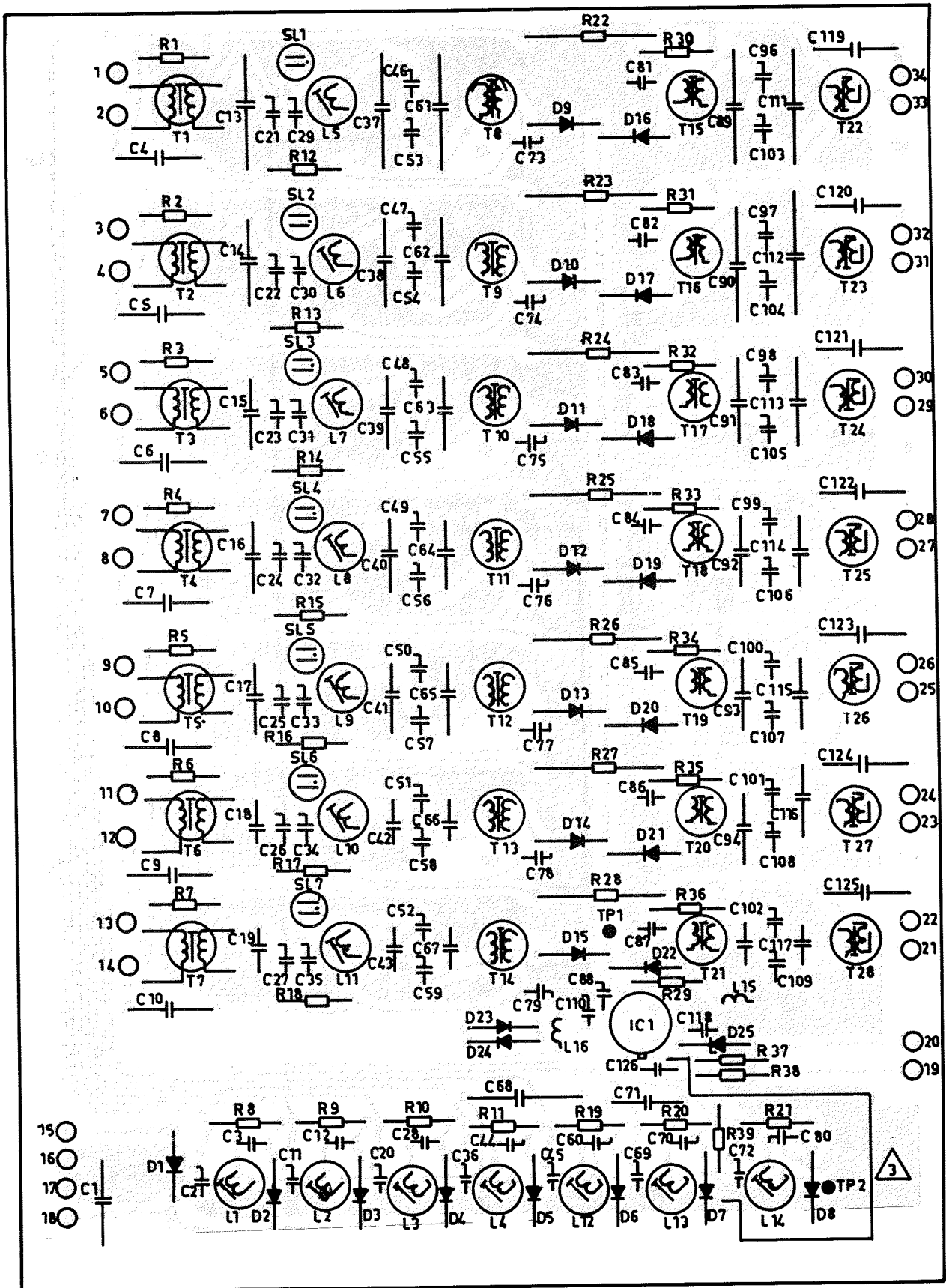

PRINTED CIRCUIT BOARD VIEWED FROM COMPONENT SIDE

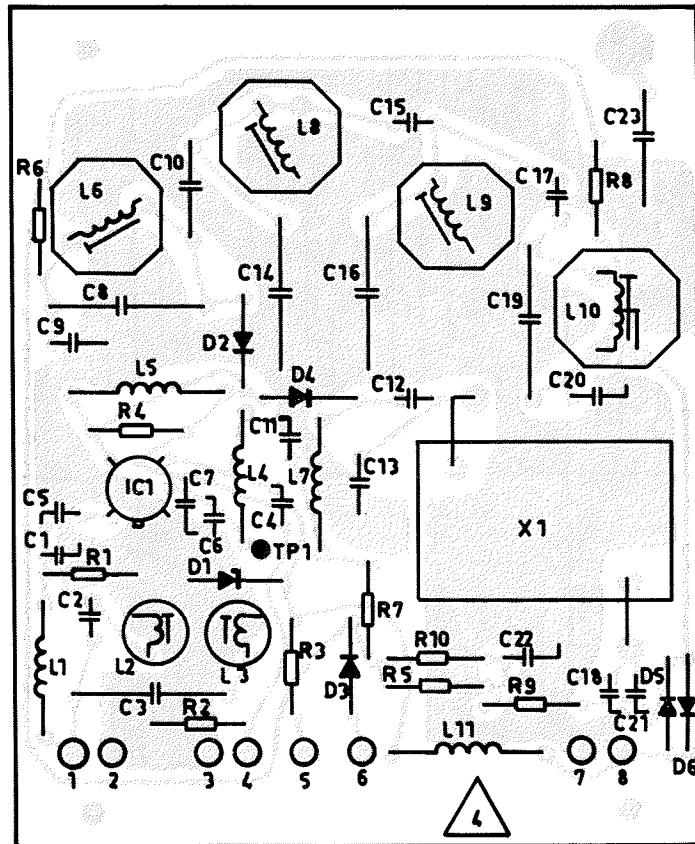

PRINTED CIRCUIT BOARD VIEWED FROM COMPONENT SIDE

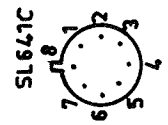
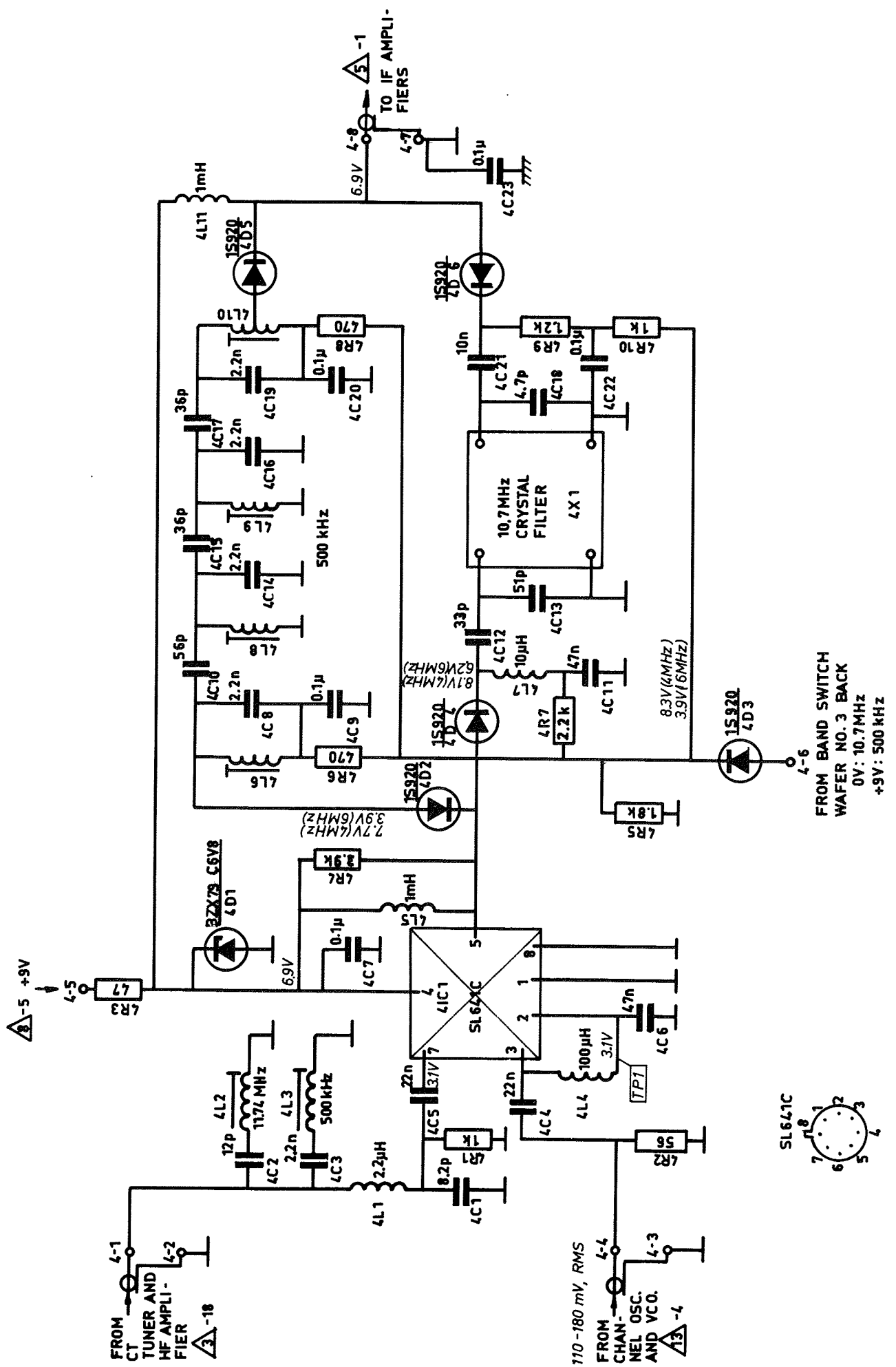

BOTTOM VIEW

1. MIXER

R-0116-1



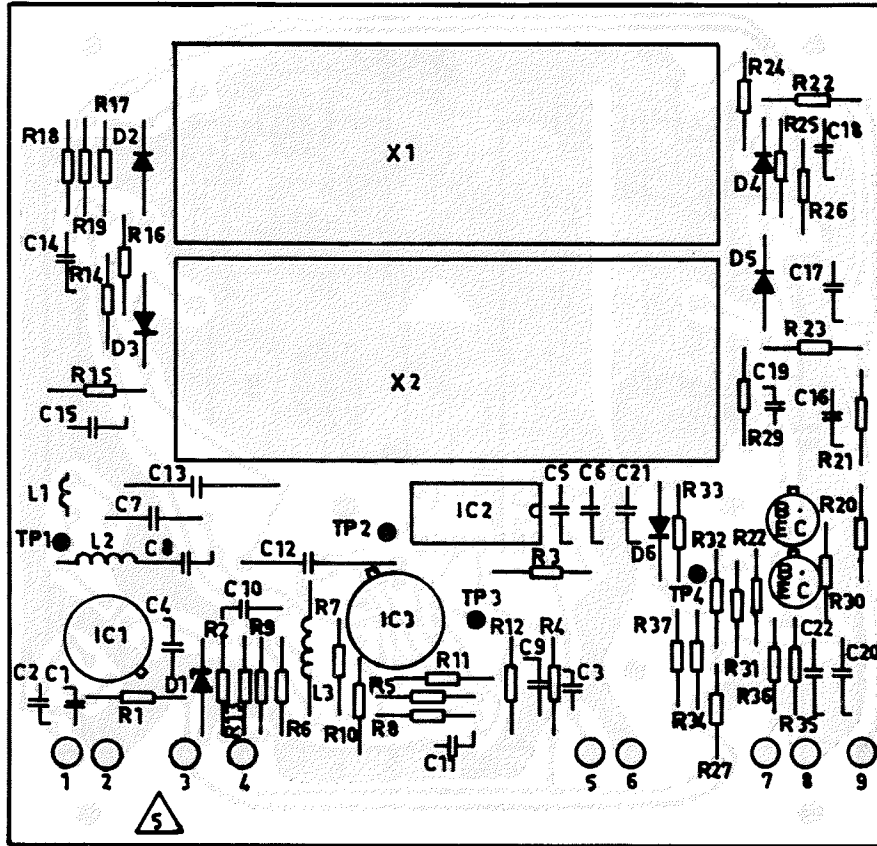

PRINTED CIRCUIT BOARD VIEWED FROM COMPONENT SIDE

1.4MHz IF AMPLIFIER

2. MIXER

0.5/10.7MHz IF AMPLIFIER

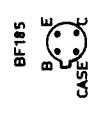
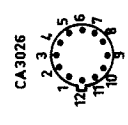
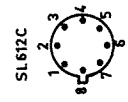
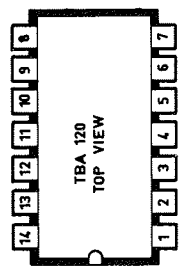
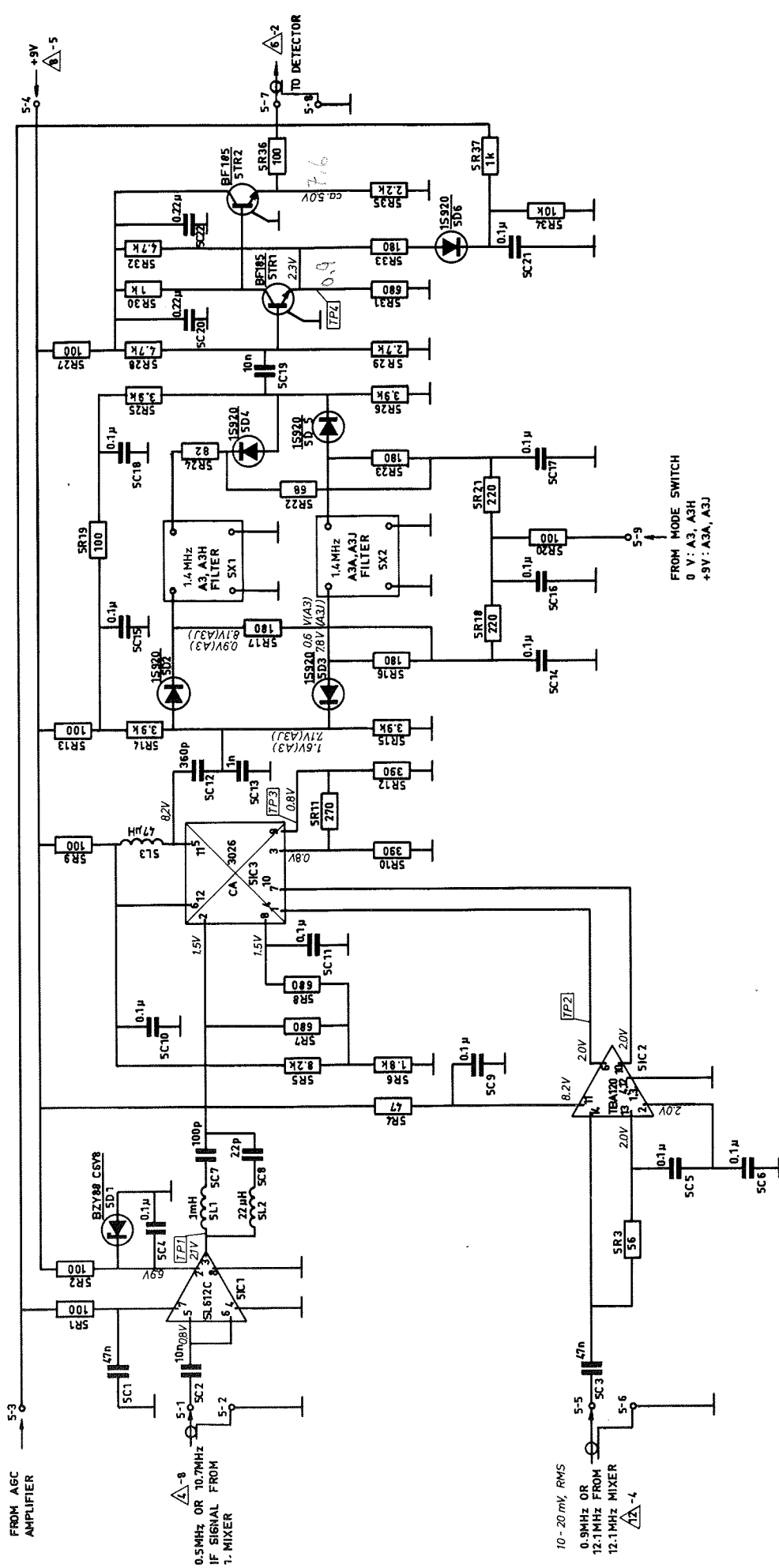

BOTTOM VIEW

10 - 20 mV_{RMS}
0.9MHz OR
12.1MHz FROM
12.1MHz MIXER
A-4

FROM MODE SWITCH
0 V: A3, A3H
+5V: A3A, A3J

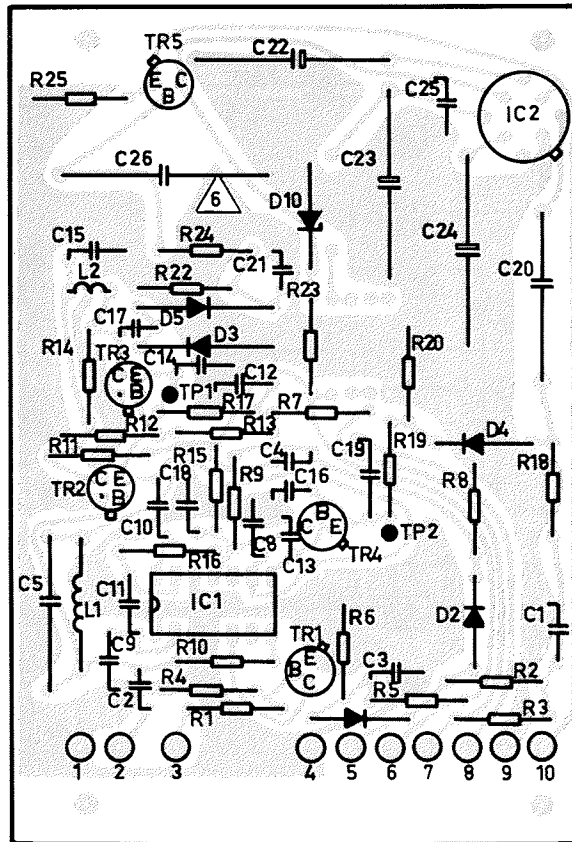

PRINTED CIRCUIT BOARD VIEWED FROM COMPONENT SIDE

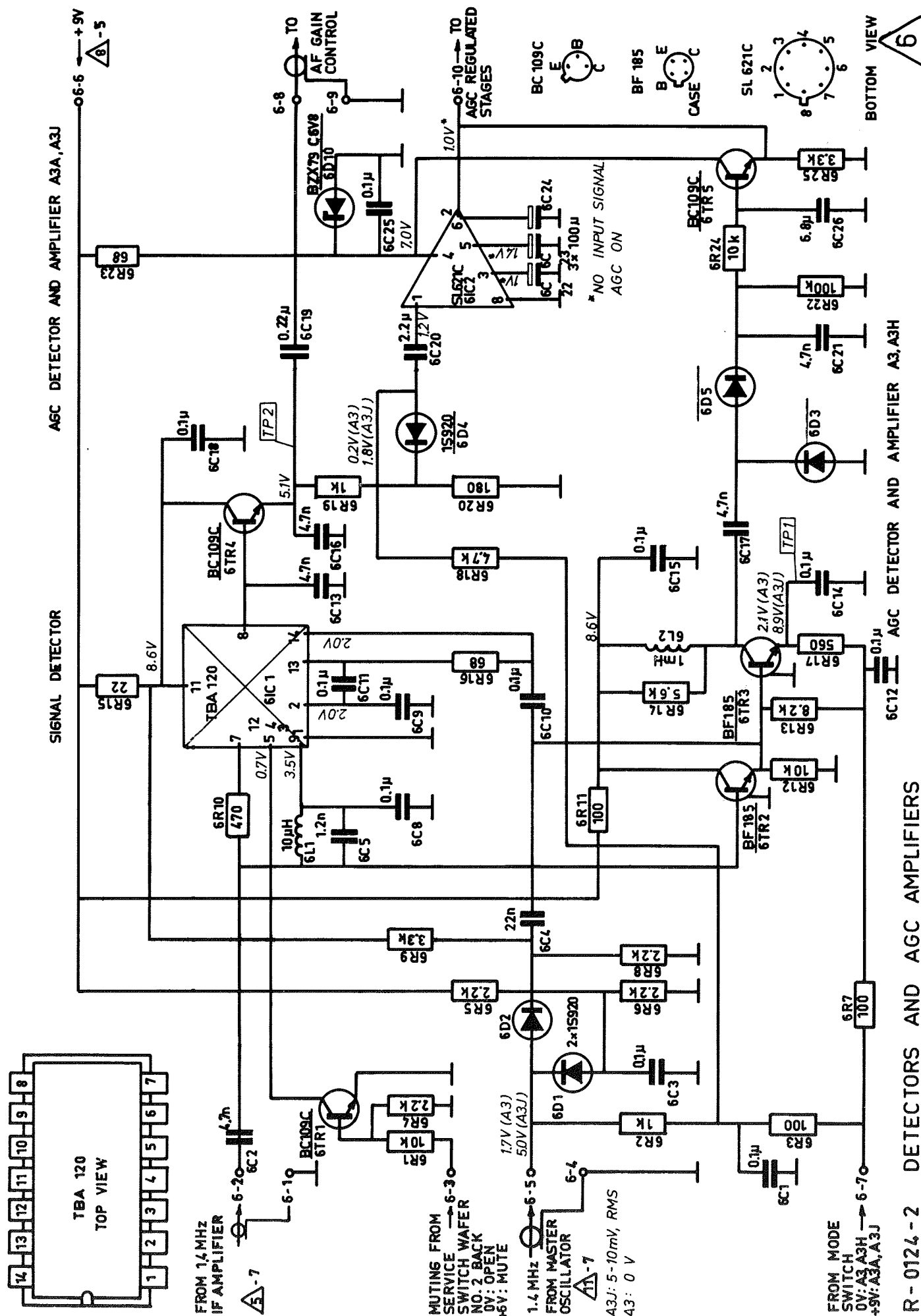

R-0124-2 DETECTORS AND AGC AMPLIFIERS

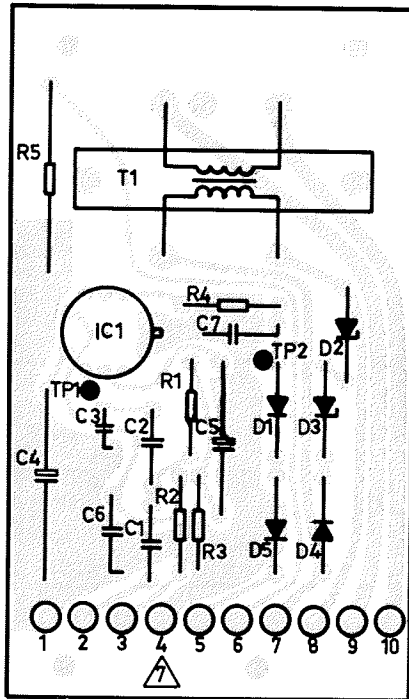

PRINTED CIRCUIT BOARD VIEWED FROM COMPONENT SIDE

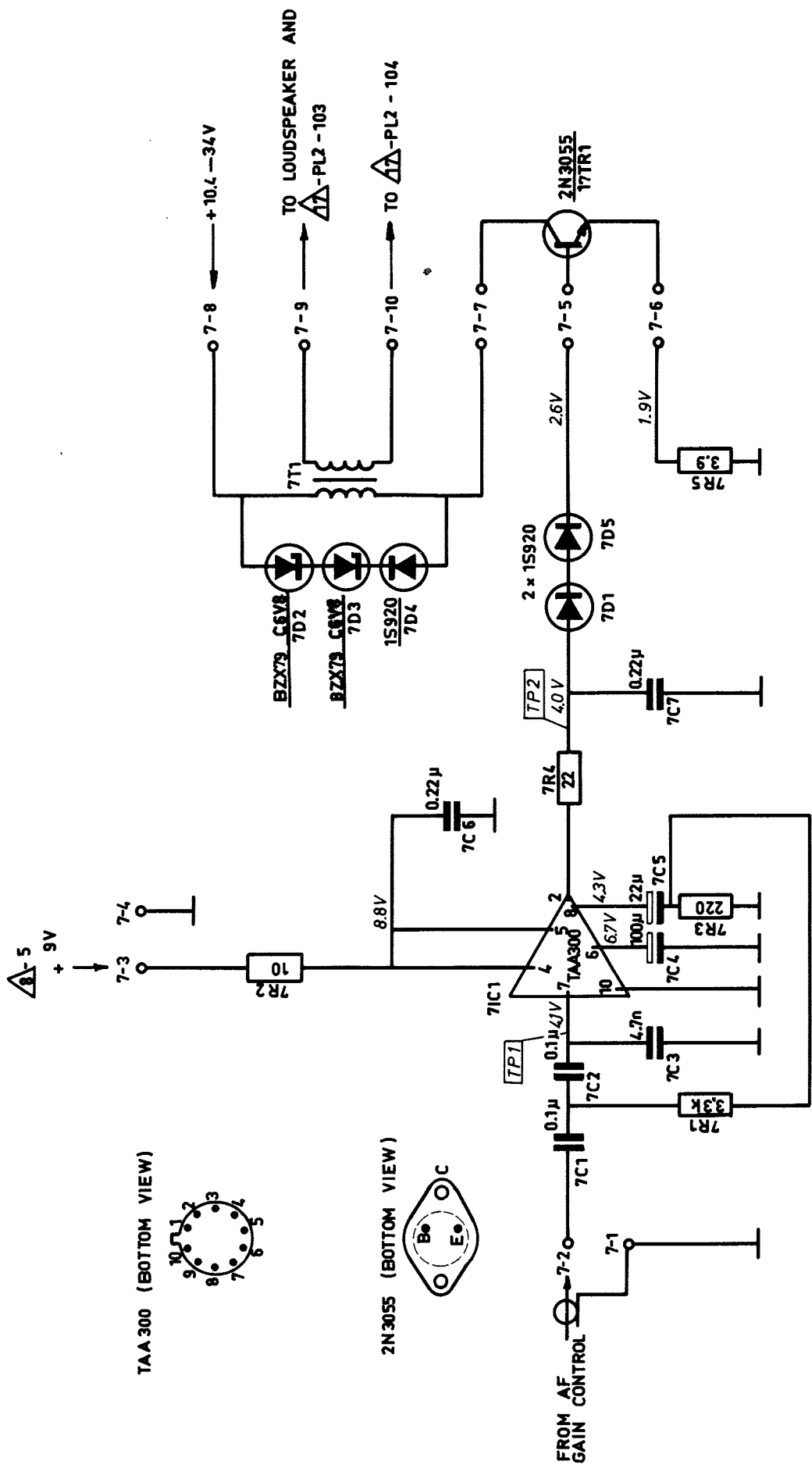

TAA 300 (BOTTOM VIEW)

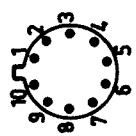

2N3055 (BOTTOM VIEW)



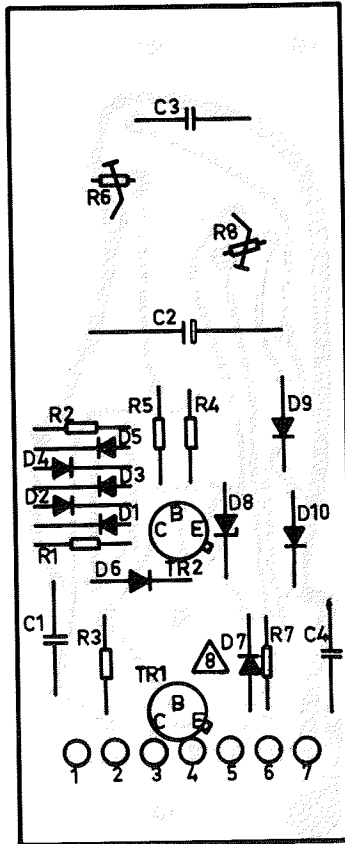

PRINTED CIRCUIT BOARD VIEWED FROM COMPONENT SIDE

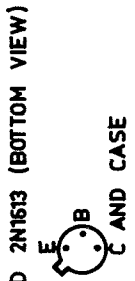
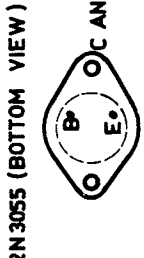
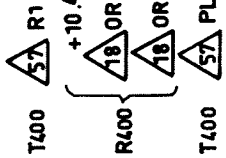
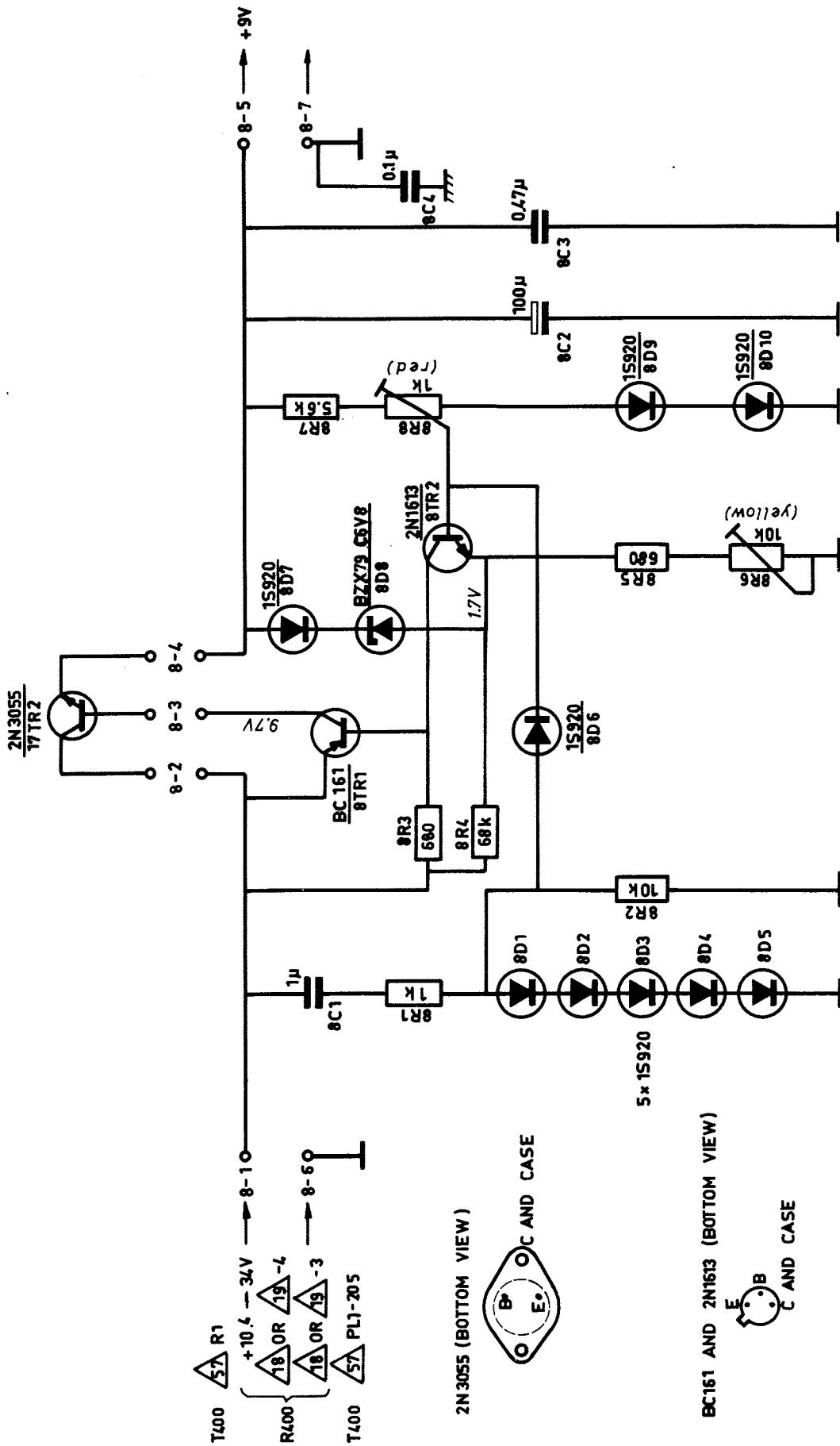

R-0132 - 1 9V VOLTAGE REGULATOR

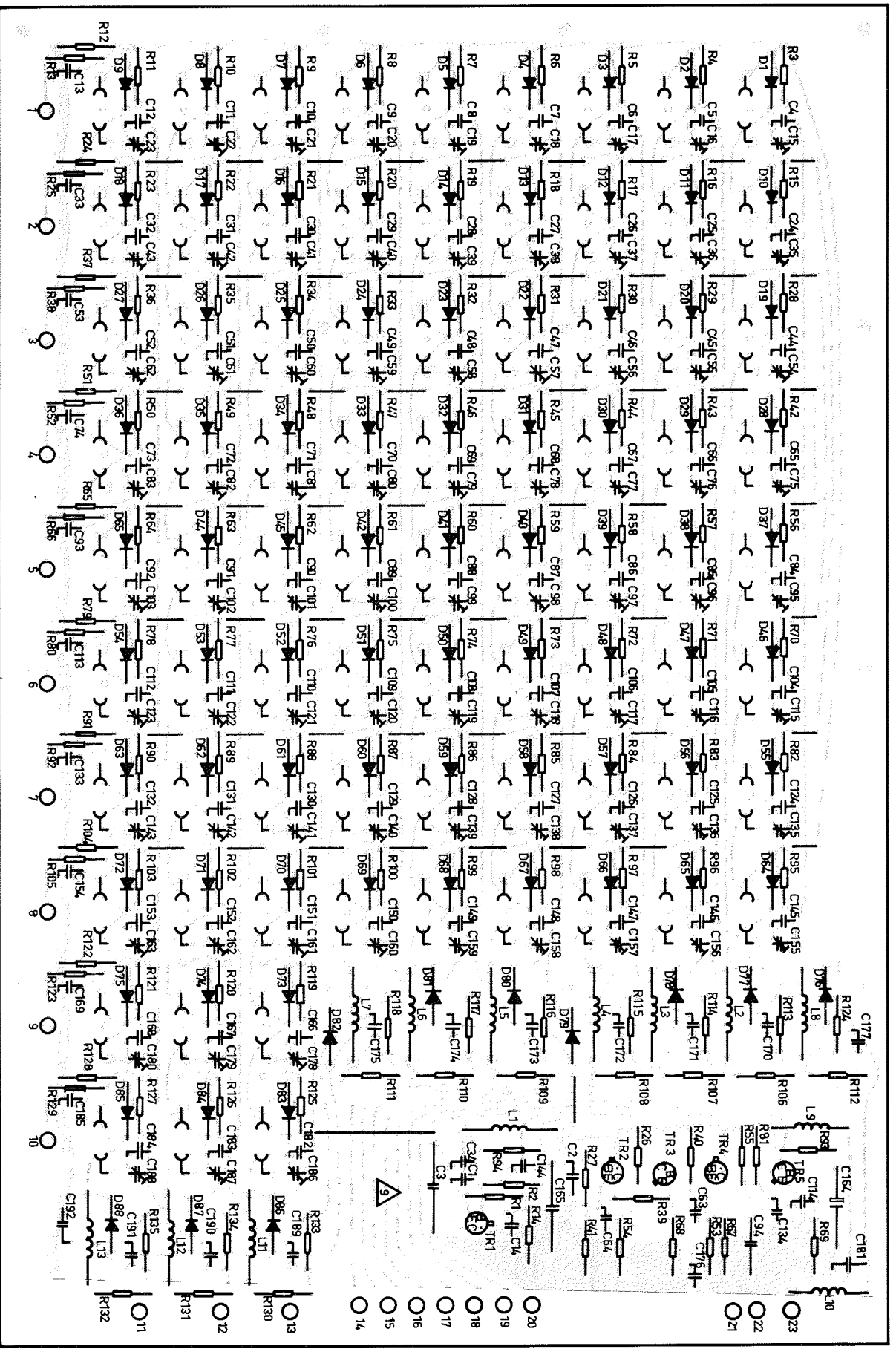

PRINTED CIRCUIT BOARD VIEWED FROM COMPONENT SIDE

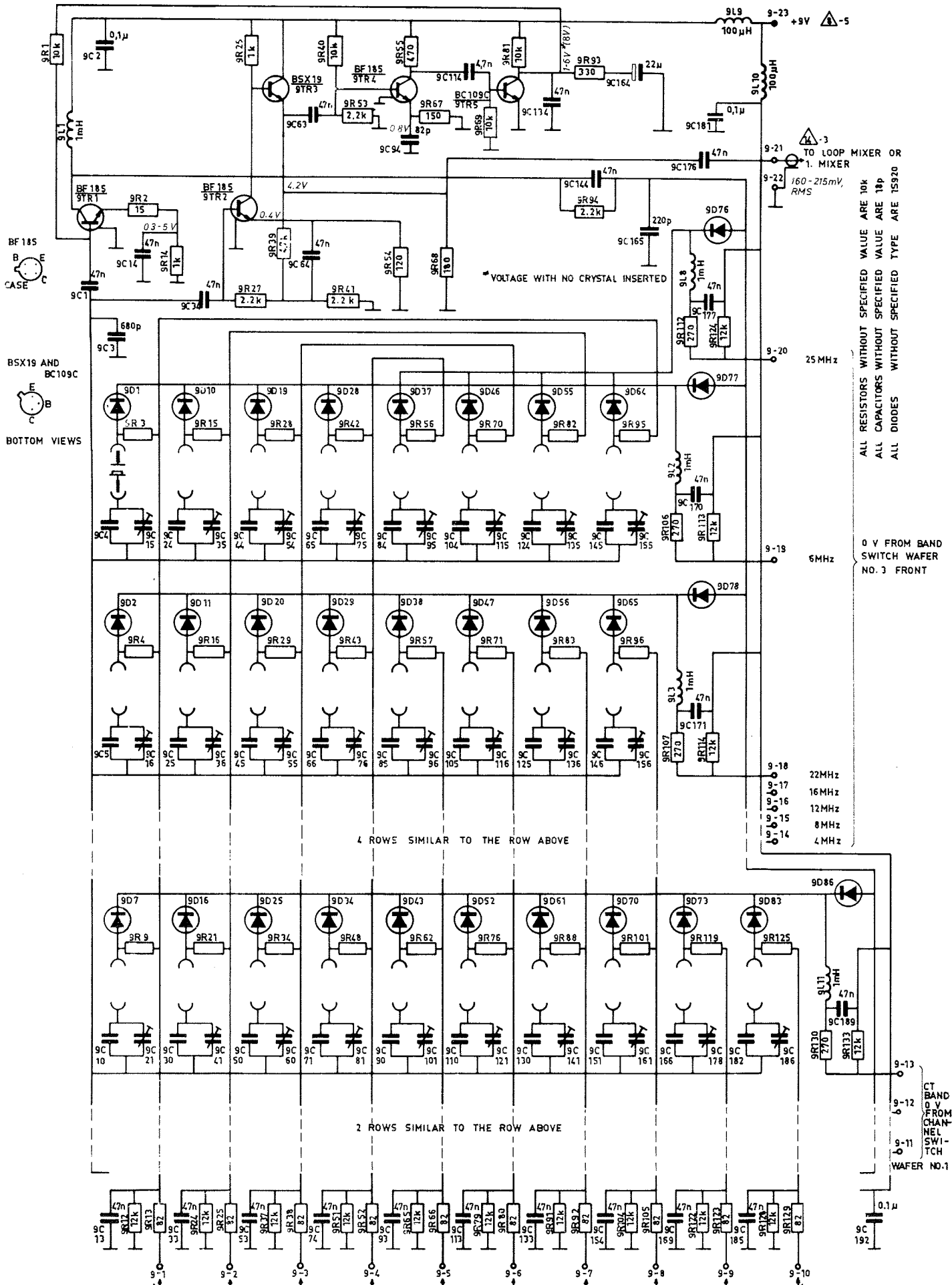

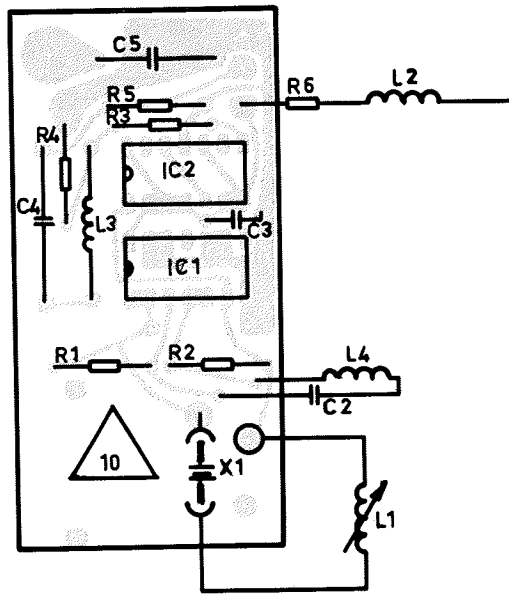

PRINTED CIRCUIT BOARD VIEWED FROM COMPONENT SIDE

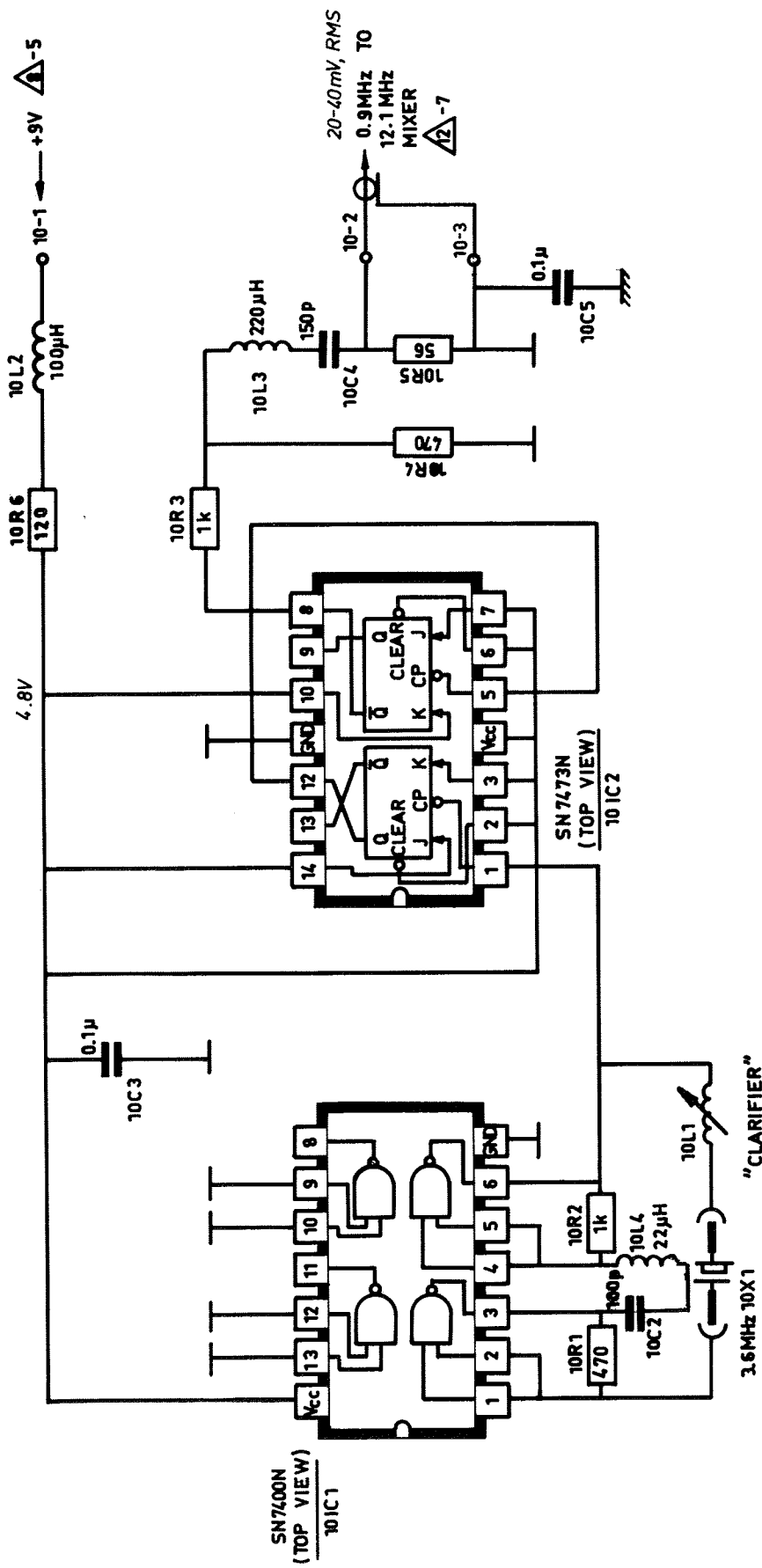

R-0140-4 CLARIFIER OSCILLATOR

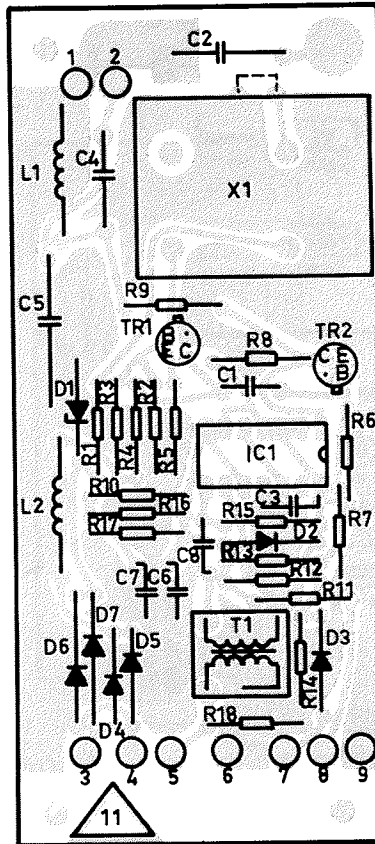

PRINTED CIRCUIT BOARD VIEWED FROM COMPONENT SIDE

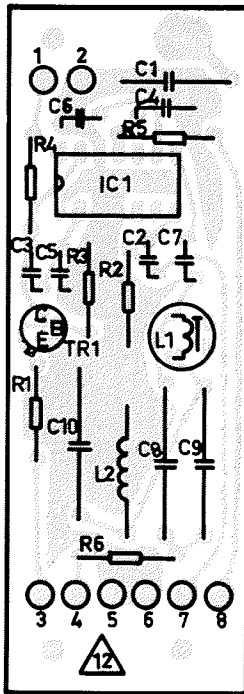

PRINTED CIRCUIT BOARD VIEWED FROM COMPONENT SIDE

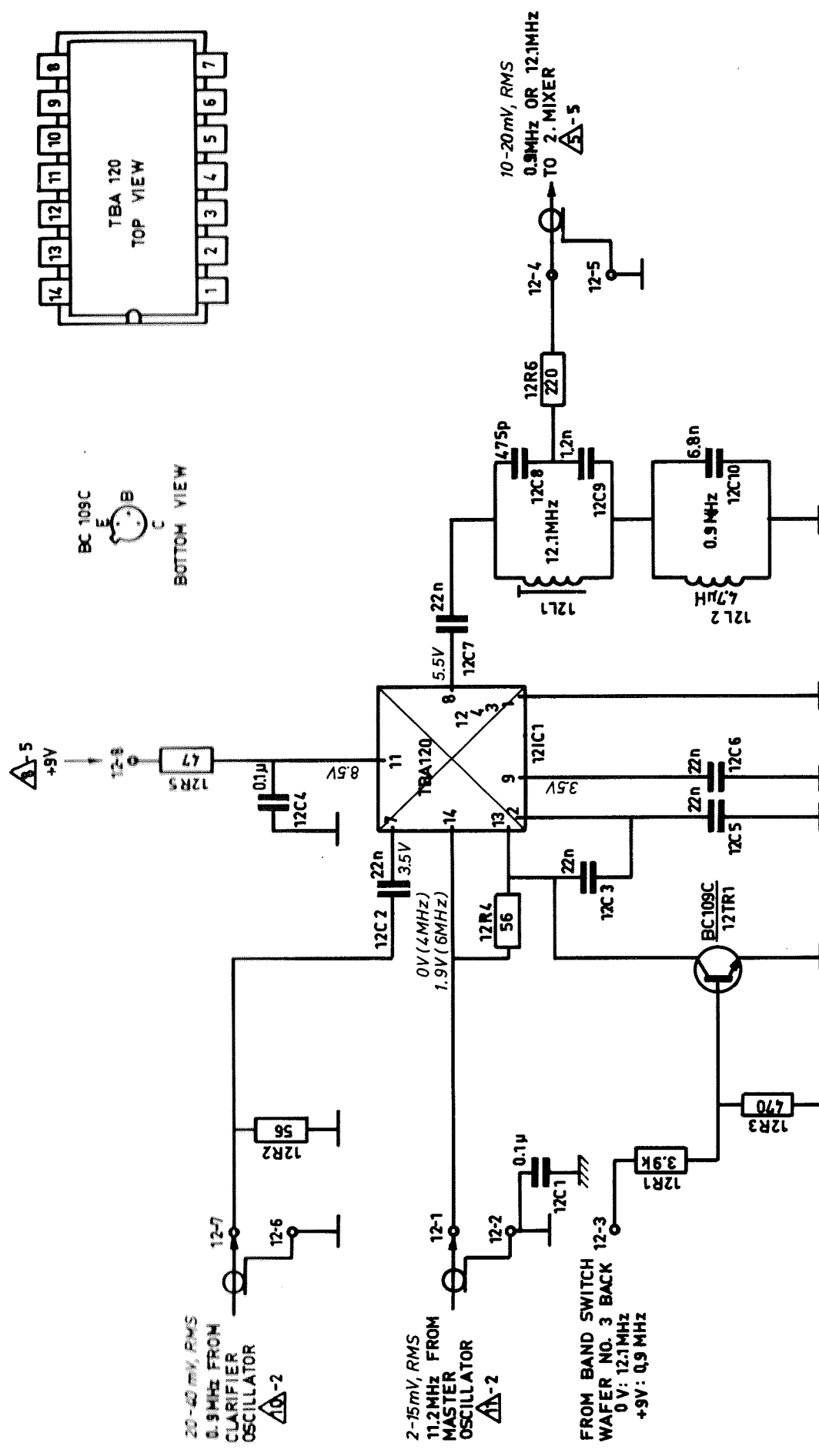

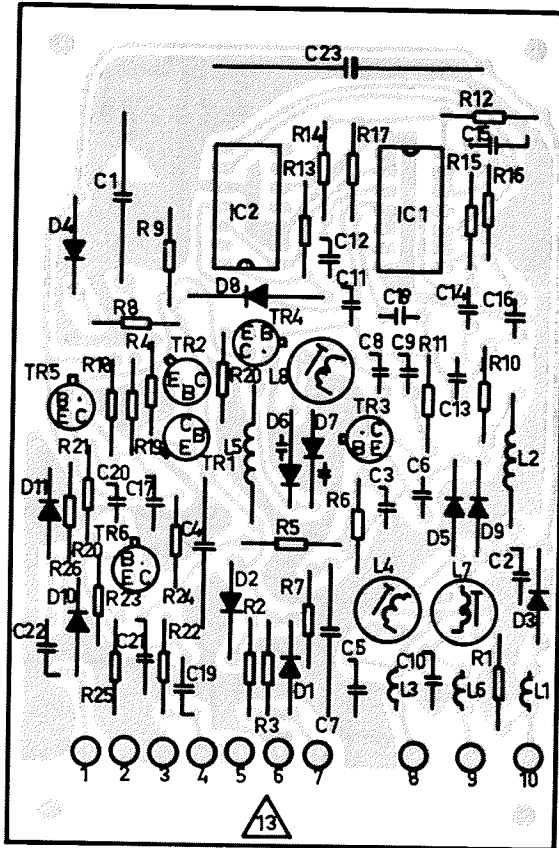

PRINTED CIRCUIT BOARD VIEWED FROM COMPONENT SIDE

FROM BAND SWITCH WAFER NO. 3 BACK
 +9V: 22MHz BAND +9V: 25MHz BAND
 0V: OTHER BANDS 0V: OTHER BANDS

AMPLITUDE REGULATOR

BUFFER AMPLIFIER

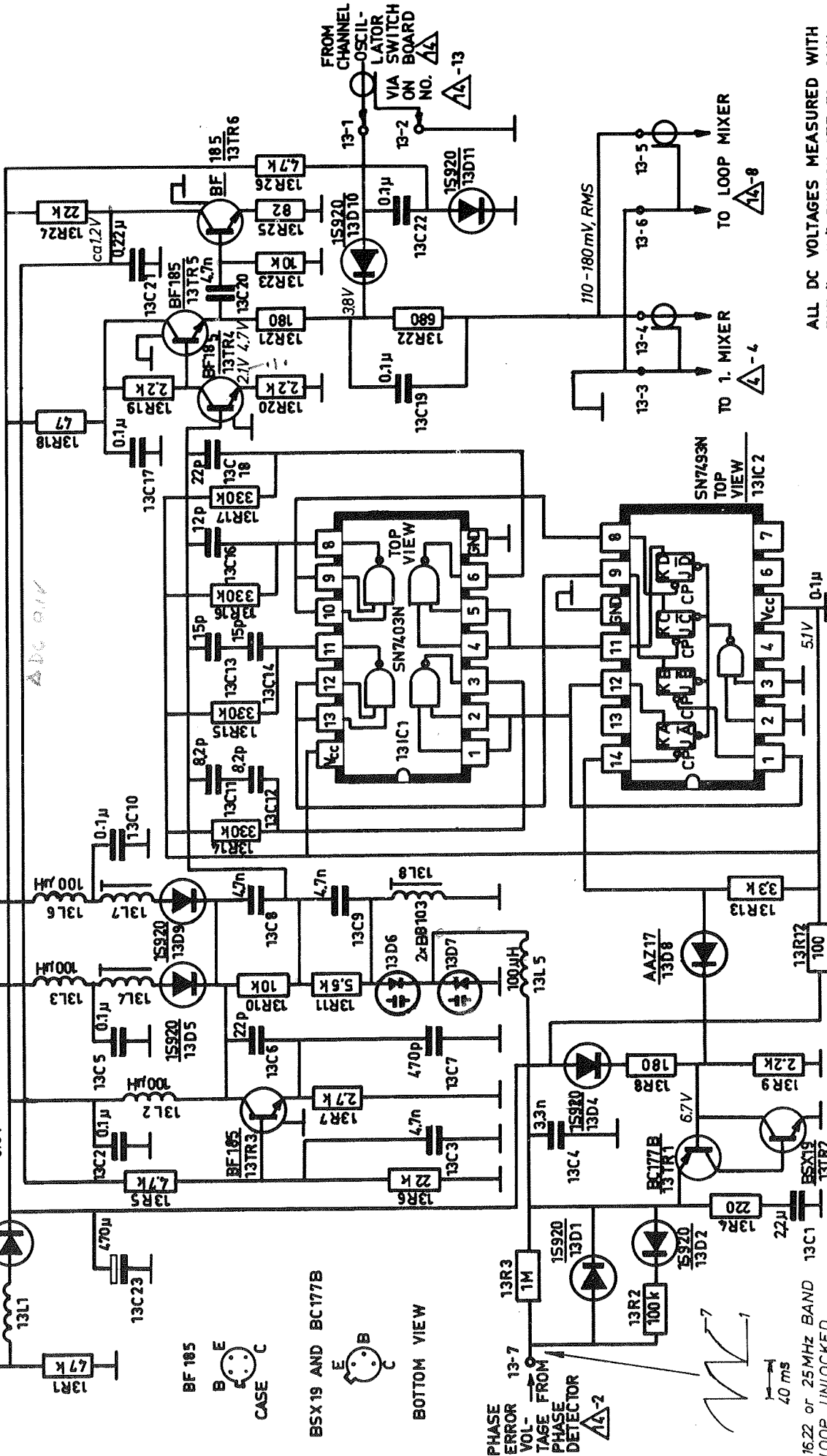

13-10 +9V: 16MHz BAND
 0V: OTHER BANDS

13-9 +9V: 22MHz BAND +9V: 25MHz BAND
 0V: OTHER BANDS

13-8 +9V: 22MHz BAND +9V: 25MHz BAND
 0V: OTHER BANDS

13-7 +9V: 22MHz BAND +9V: 25MHz BAND
 0V: OTHER BANDS

13-6 +9V: 22MHz BAND +9V: 25MHz BAND
 0V: OTHER BANDS

13-5 +9V: 22MHz BAND +9V: 25MHz BAND
 0V: OTHER BANDS

13-4 +9V: 22MHz BAND +9V: 25MHz BAND
 0V: OTHER BANDS

13-3 +9V: 22MHz BAND +9V: 25MHz BAND
 0V: OTHER BANDS

13-2 +9V: 22MHz BAND +9V: 25MHz BAND
 0V: OTHER BANDS

13-1 +9V: 22MHz BAND +9V: 25MHz BAND
 0V: OTHER BANDS

13-0 +9V: 22MHz BAND +9V: 25MHz BAND
 0V: OTHER BANDS

13-1 FROM CHANNEL OSCILLATOR VIA SWITCH ON BOARD NO. 1A-13

13-2 TO 1. MIXER 1A-4

13-3 TO 1. MIXER 1A-4

13-4 TO 1. MIXER 1A-4

13-5 TO LOOP MIXER 1A-8

13-6 TO LOOP MIXER 1A-8

13-7 TO LOOP MIXER 1A-8

13-8 TO LOOP MIXER 1A-8

13-9 TO LOOP MIXER 1A-8

13-10 TO LOOP MIXER 1A-8

13-11 TO LOOP MIXER 1A-8

13-12 TO LOOP MIXER 1A-8

13-13 TO LOOP MIXER 1A-8

13-14 TO LOOP MIXER 1A-8

13-15 TO LOOP MIXER 1A-8

13-16 TO LOOP MIXER 1A-8

13-17 TO LOOP MIXER 1A-8

13-18 TO LOOP MIXER 1A-8

13-19 TO LOOP MIXER 1A-8

13-20 TO LOOP MIXER 1A-8

13-21 TO LOOP MIXER 1A-8

13-22 TO LOOP MIXER 1A-8

13-23 TO LOOP MIXER 1A-8

13-24 TO LOOP MIXER 1A-8

13-25 TO LOOP MIXER 1A-8

13-26 TO LOOP MIXER 1A-8

13-27 TO LOOP MIXER 1A-8

13-28 TO LOOP MIXER 1A-8

13-29 TO LOOP MIXER 1A-8

13-30 TO LOOP MIXER 1A-8

ALL DC VOLTAGES MEASURED WITH THE "BAND" SWITCH SET TO 16MHz

STEP GENERATOR

HUNTING OSCILLATOR

R-0152 - 2 VOLTAGE CONTROLLED OSCILLATOR

16.22 or 25MHz BAND LOOP UNLOCKED (EG: CHANNEL 9)

40 ms



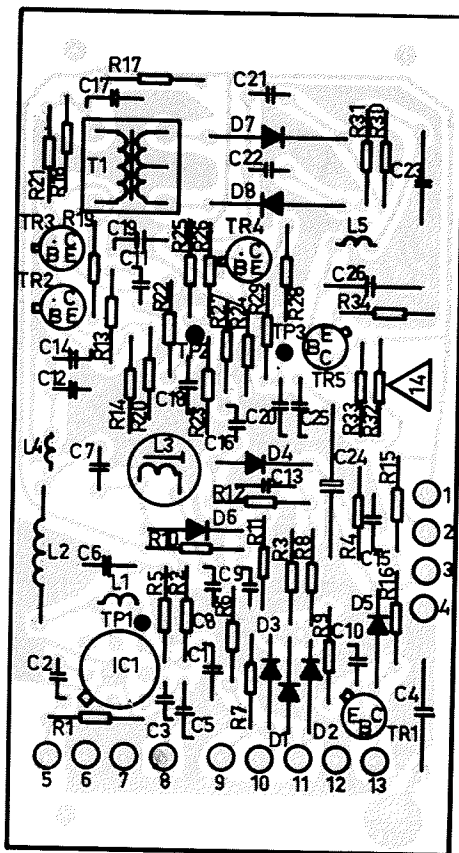

PRINTED CIRCUIT BOARD VIEWED FROM COMPONENT SIDE

AC VOLTAGES APPLIES FOR THE 1622 AND 25MHZ BANDS AND LOCKED LOOP

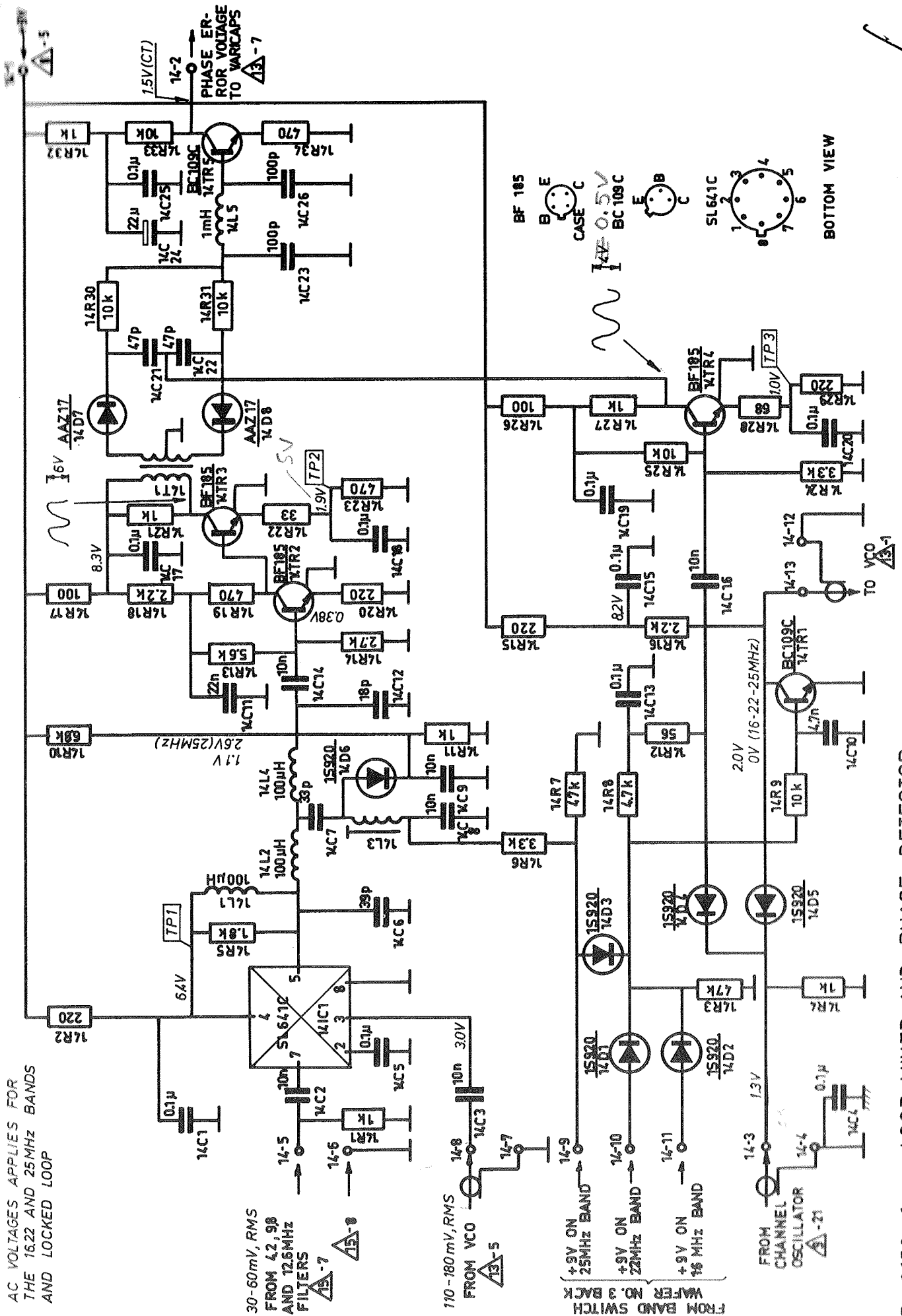

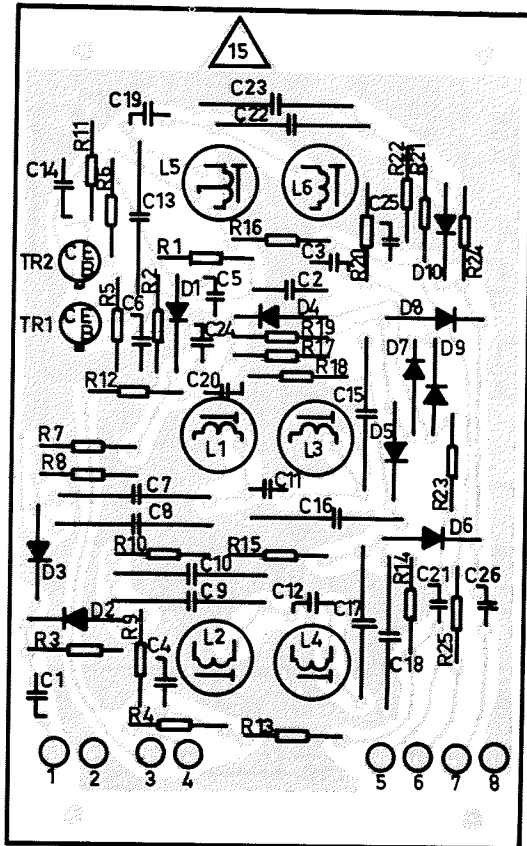

PRINTED CIRCUIT BOARD VIEWED FROM COMPONENT SIDE

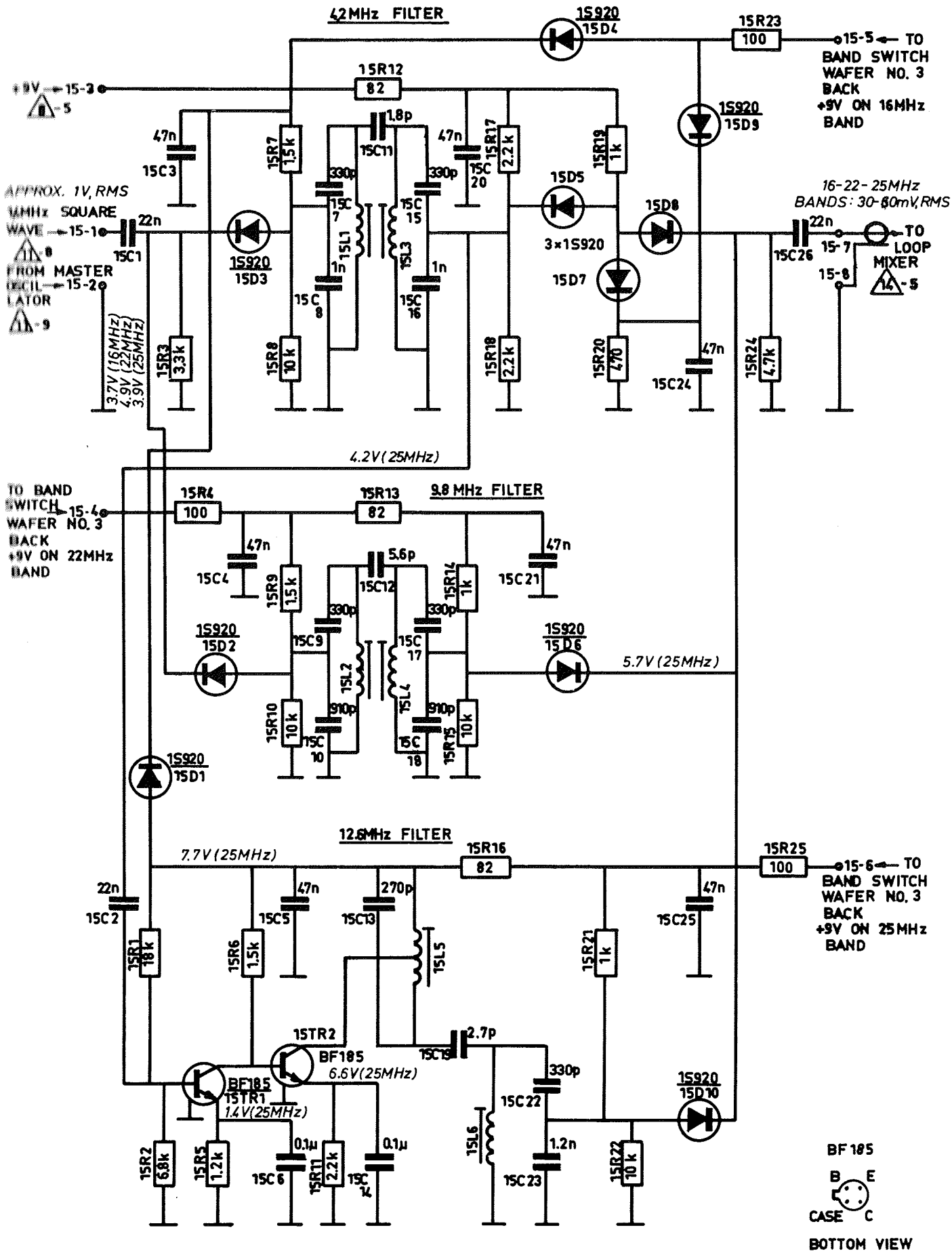

R-0160-1 FILTERS FOR 4.2-9.8 AND 12.6 MHz



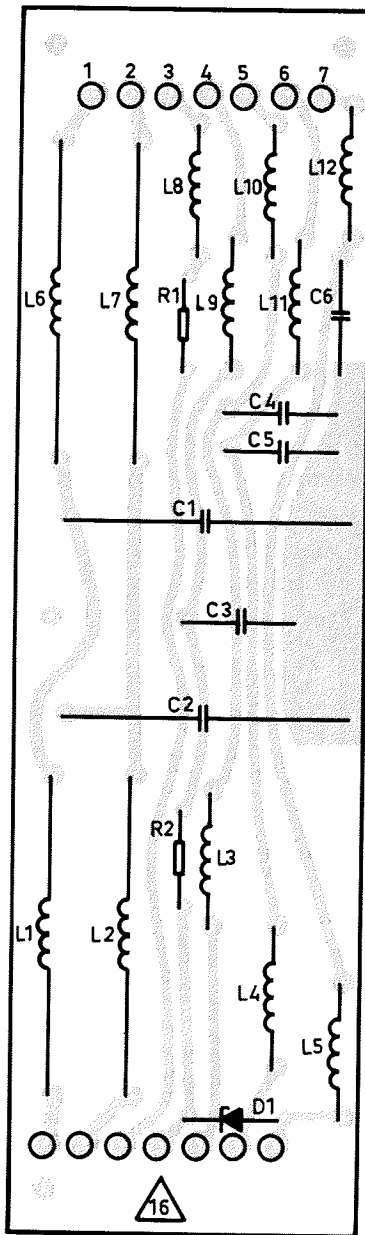

PRINTED CIRCUIT BOARD VIEWED FROM COMPONENT SIDE

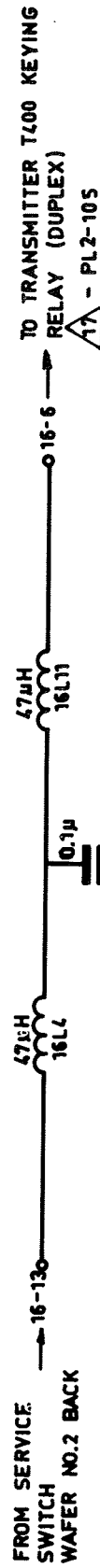
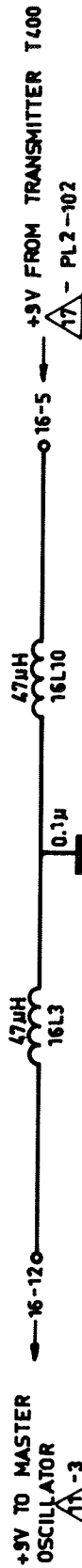
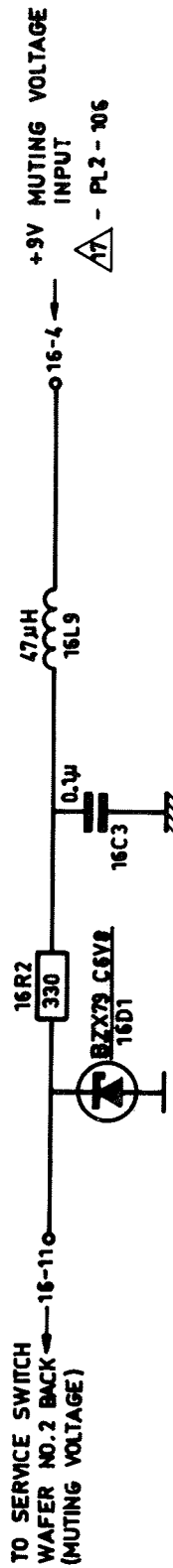
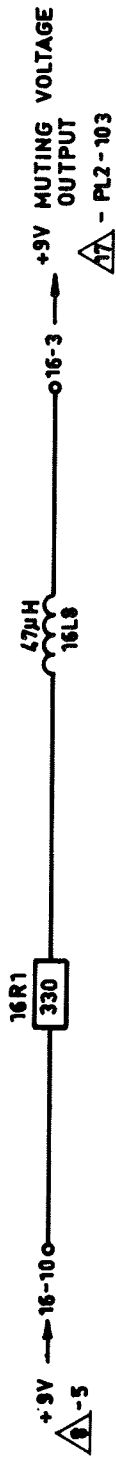
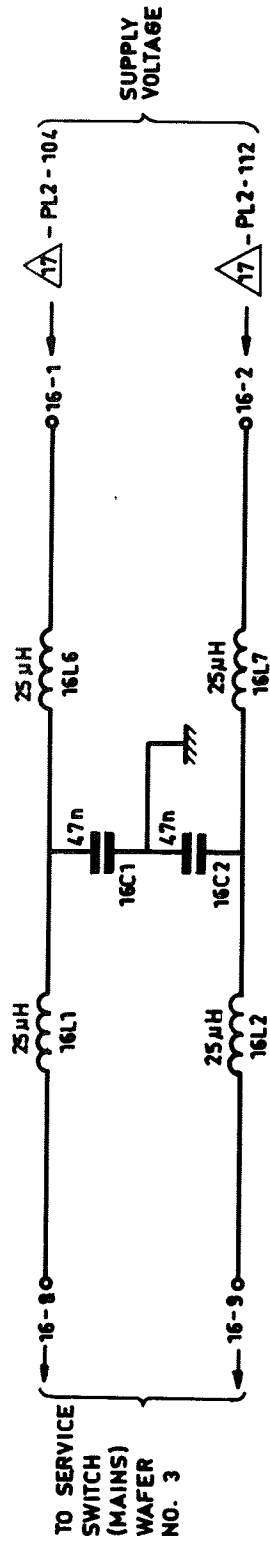

R-0164 -1 RF1 FILTERS

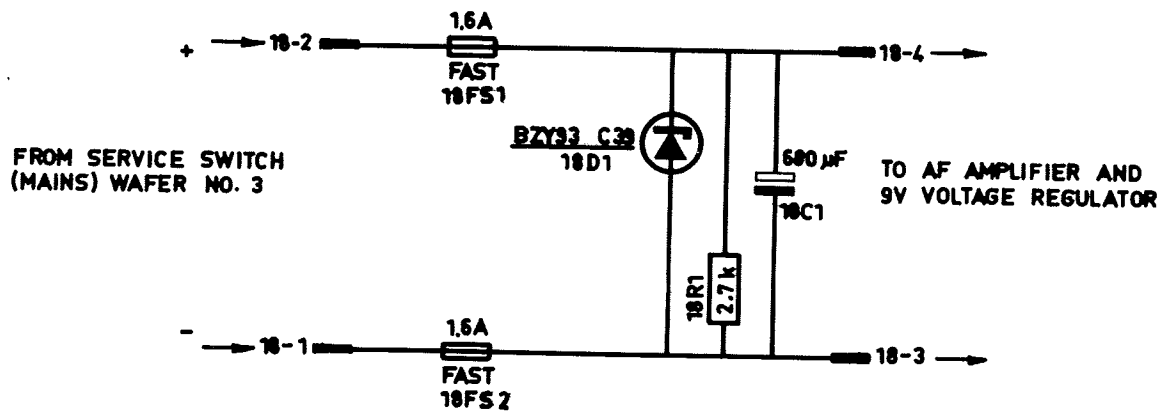

AC SUPPLY VOLTAGE	F1
110V	315mA
220V	160mA
380V	80mA
440V	80mA

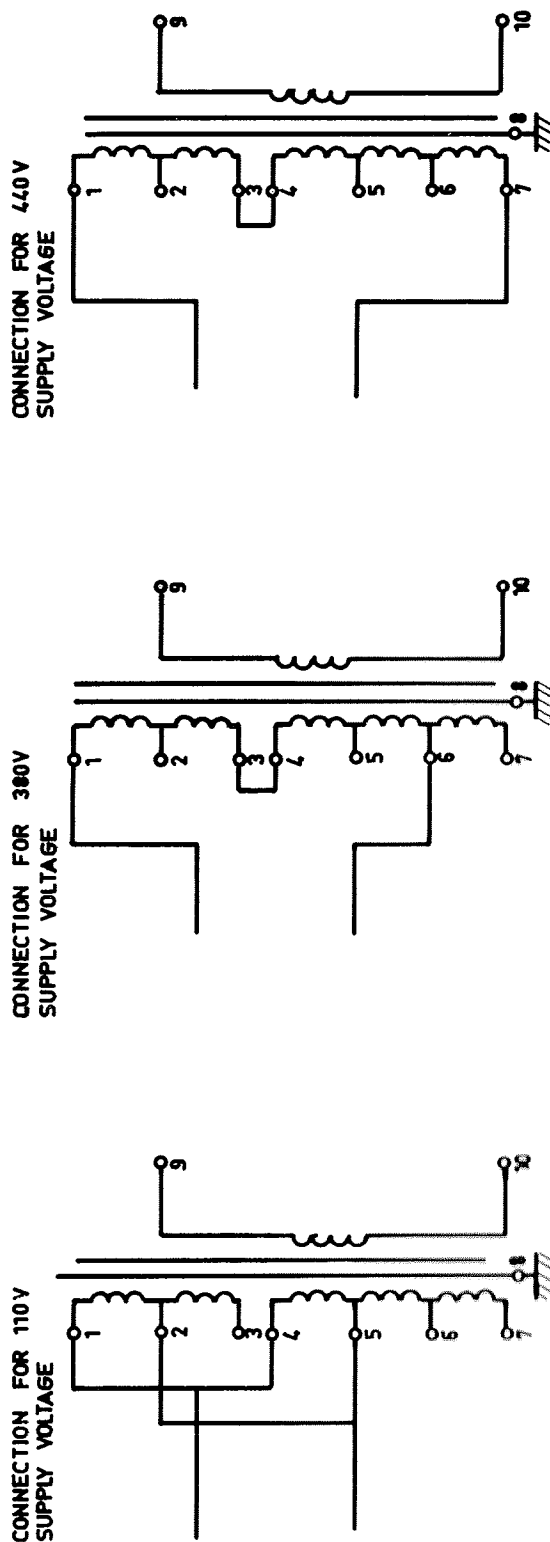
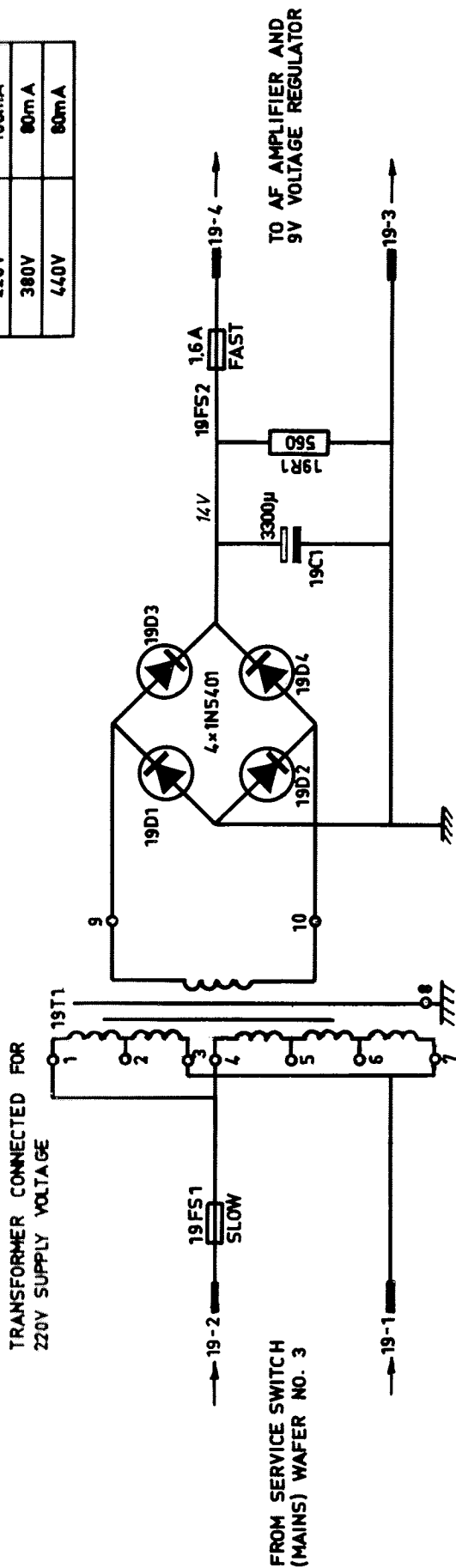

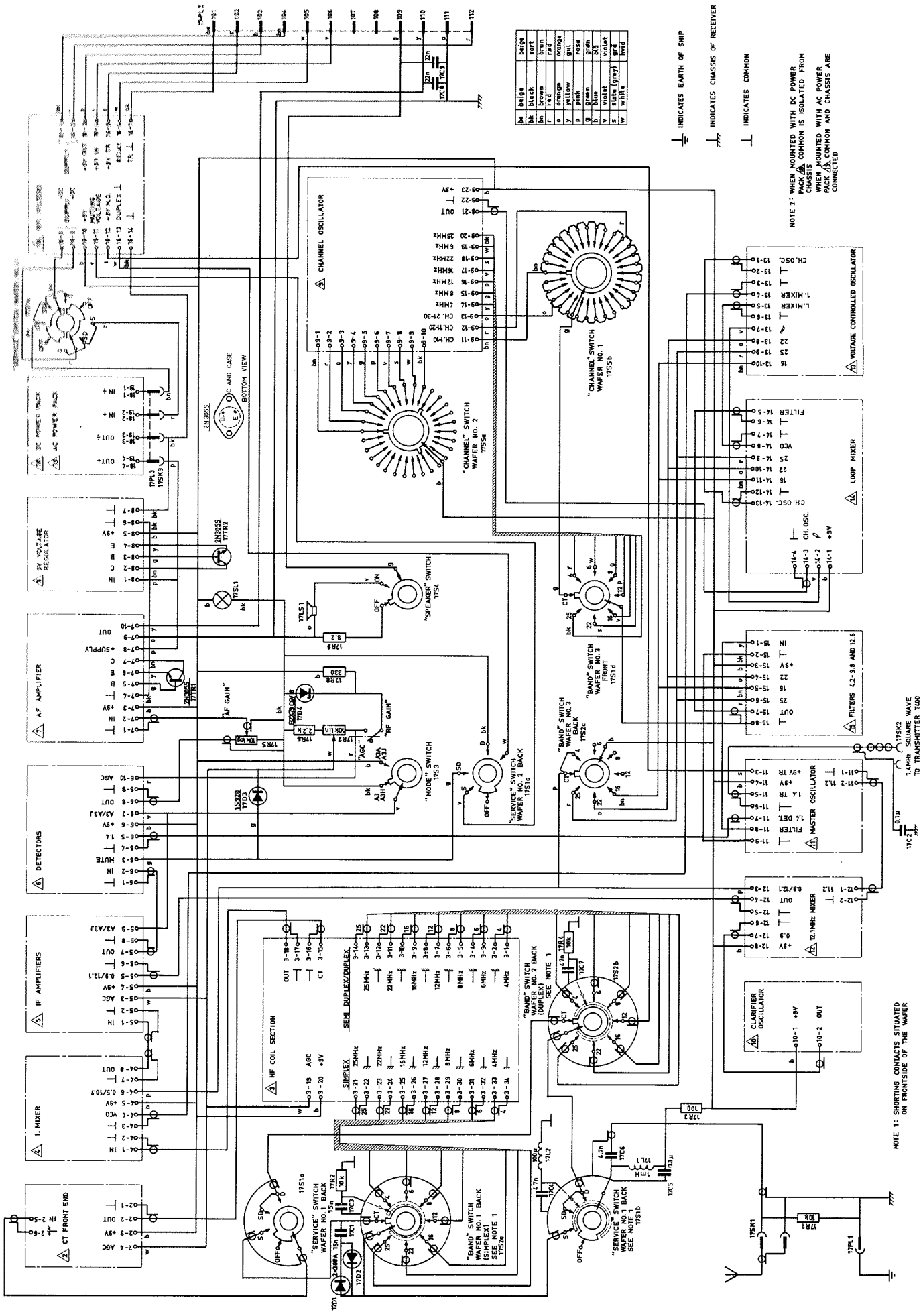

be	beige
bk	black
bn	brown
r	red
o	orange
y	yellow
p	pink
g	green
b	blue
v	violet
s	slate (grey)
w	white
lv	lavender

⊥ INDICATES EARTH OF SHIP
 ⊥ INDICATES CHASSIS OF RECEIVER
 ⊥ INDICATES COMMON

NOTE 2: WHEN MOUNTED WITH DC POWER CHASSIS COMMON IS ISOLATED FROM CHASSIS
 WHEN MOUNTED WITH AC POWER PACK CHASSIS COMMON AND CHASSIS ARE CONNECTED

NOTE 1: SHORTING CONTACTS SITUATED ON FRONTSIDE OF THE WAFER